

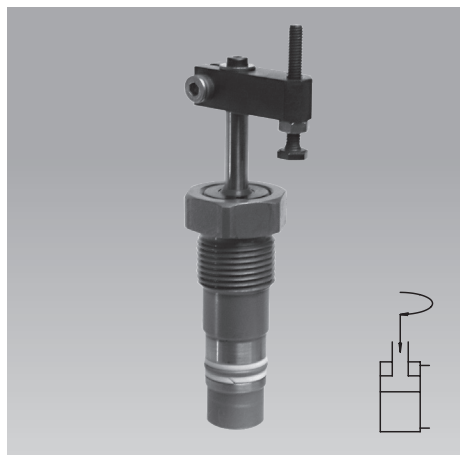

**Mini Swing Clamps with Sturdy Swing Mechanism**  
threaded-body type,  
double acting, max. operating pressure 150 bar



**Advantages**

- Minimum dimensions
- Double-acting function
- Sturdy swing mechanism
- Oil supply through drilled channels
- Built-in housing of tube connecting thread available
- Installation as cartridge type by accessory flange
- Simple fixing of clamping arm
- Clamping arm for clamping with minimum deformation available
- Unimpeded loading and unloading of the fixture
- Mounting position: variable
- Standard FKM seals
- Maintenance free

**Clamping principle**

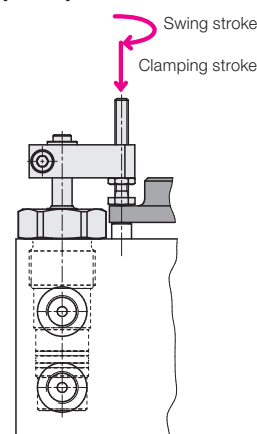

**Application**

Hydraulic swing clamps are used for clamping of workpieces, when it is essential to keep the clamping area free of straps and clamping components for unrestricted workpiece loading and unloading.

Mini swing clamps are particularly suitable for machining of thin-walled workpieces, which require only little clamping forces.

Mini swing clamps are an interesting alternative for pneumatic clamping elements, since they require less space.

**Description**

This double-acting mini swing clamp works as pull-type cylinder where a part of the total stroke is used to swing the piston.

Clockwise and counterclockwise versions are available with an swing angle of 90, 60 and 45 degrees. The 0 degree version can be used as push and pull-type cylinder with anti-rotation piston.

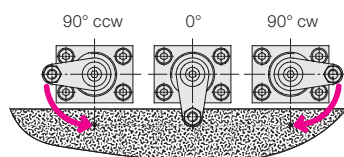

The clamping arms are locked on the piston rod. A safety screw avoids axial displacement.

**Important notes**

- Considerable injuries can be caused to fingers during clamping and unclamping in the effective area of the clamping arm.
- Remedy: protection device with electrical locking.
- Operating conditions, tolerances and other data see data sheet A 0.100.

**Installation and connecting possibilities**

**Threaded-body type**

for horizontally-drilled channels

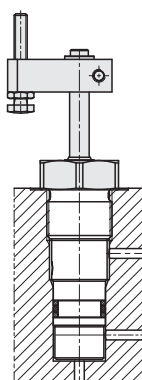

**Pipe thread**

with accessory built-in housing

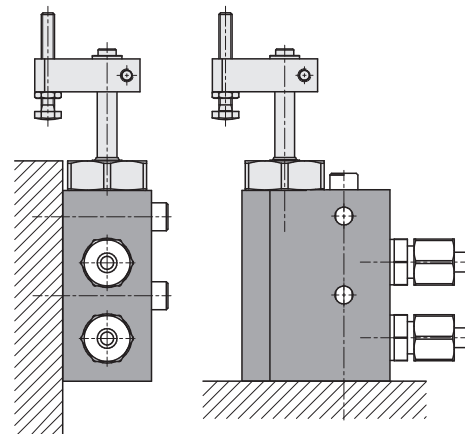

**Installation as cartridge type with accessory fixing flange**

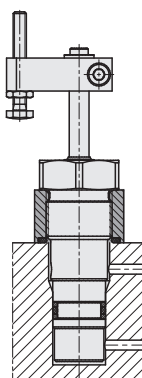

**Threaded-body type with accessory clamping strap**

for clamping with minimum deformation

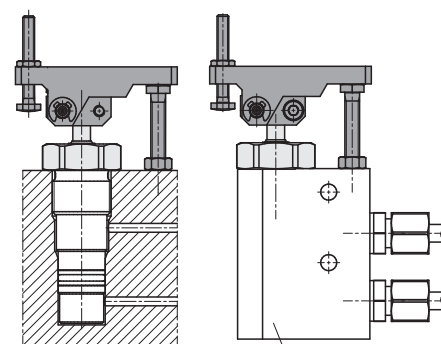

Accessory Built-in housing

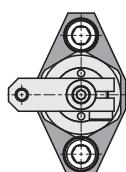

# Technical data

## Dimensions • Accessories

### Technical data

Piston Ø	[mm]	10
Rod Ø	[mm]	6
Swing stroke	[mm]	10
Clamping stroke	[mm]	8
Total stroke	[mm]	18
Effective piston area		
Clamping	[cm <sup>2</sup> ]	0,5
Unclamping	[cm <sup>2</sup> ]	0,78
Required oil per stroke		
Clamping	[cm <sup>3</sup> ]	0,91
Unclamping	[cm <sup>3</sup> ]	1,42
Max. oil flow rate		
Clamping	[cm <sup>3</sup> /s]	6
Unclamping	[cm <sup>3</sup> /s]	10
Min. operating pressure	[bar]	25
Max. operating pressure	[bar]	150
Max. pulling force	[kN]	0,75
Effective clamping force	[kN]	see diagram
Weight	[kg]	0,12

### Part numbers

Swing angle	Swing direction	Part no.
90°	CW	<b>1848 115</b>
90°	CCW	<b>1848 125</b>
60°	CW	<b>1848 135</b>
60°	CCW	<b>1848 145</b>
45°	CW	<b>1848 155</b>
45°	CCW	<b>1848 165</b>
0°	-	<b>1848 105</b>

### Clamping force diagram

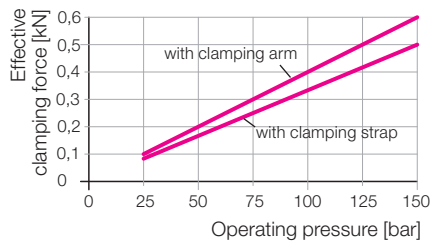

### Dimensions

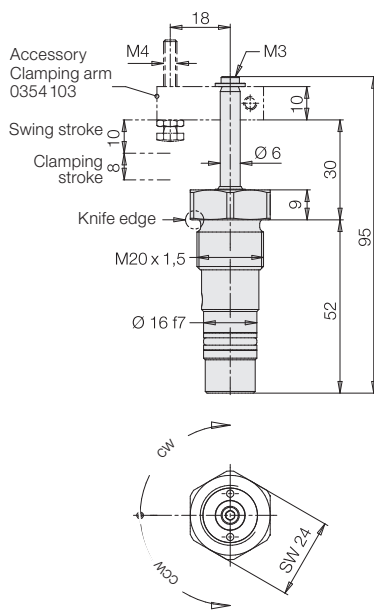

### Accessory

#### Fixing flange 0354410

Accessory  
Clamping arm  
0354 103

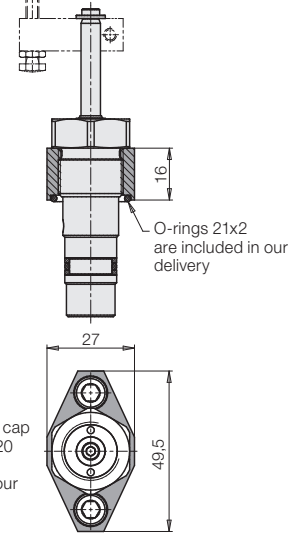

### Porting details

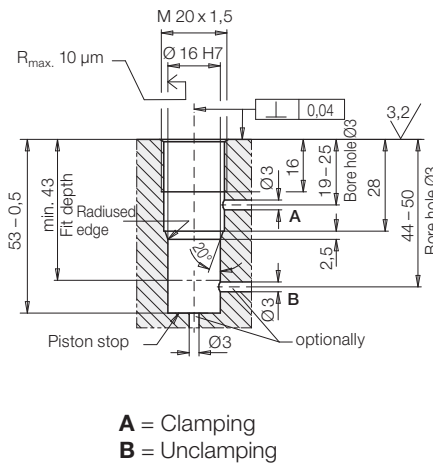

### Cartridge-type hole

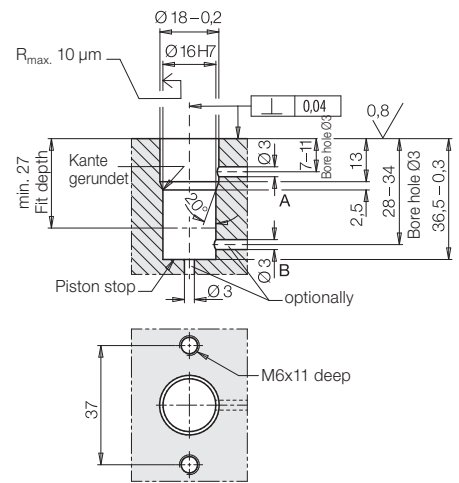

### Accessory Built-in housing 0346710

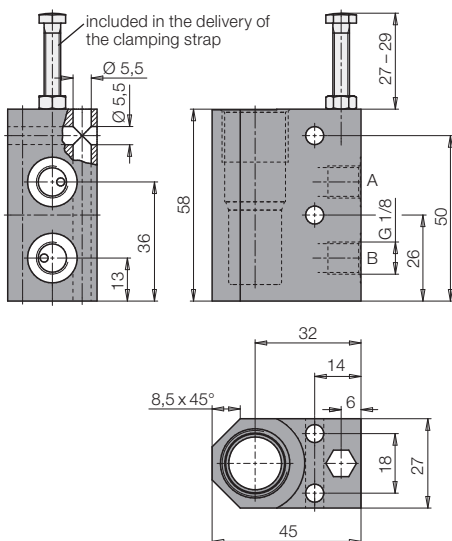

### Accessory Clamping arm 0354 103

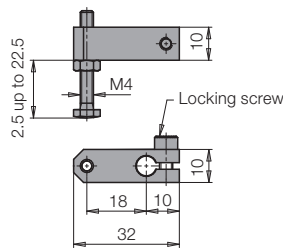

### Accessory Clamping strap for clamping with minimum deformation 0354230

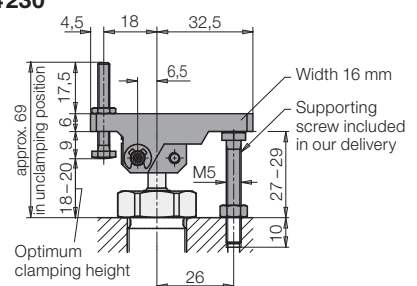

### Dimensions for special clamping arms

