

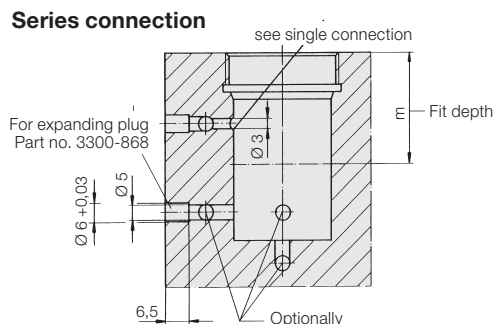

**Threaded-Body Cylinders**  
double acting  
max. operating pressure 500 bar

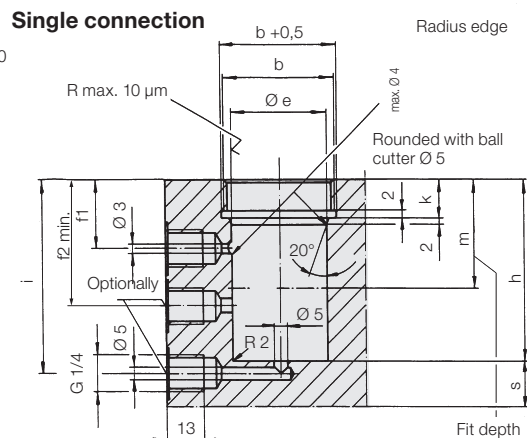
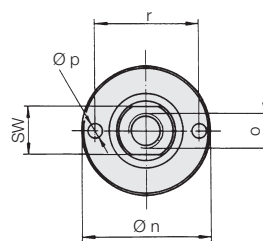
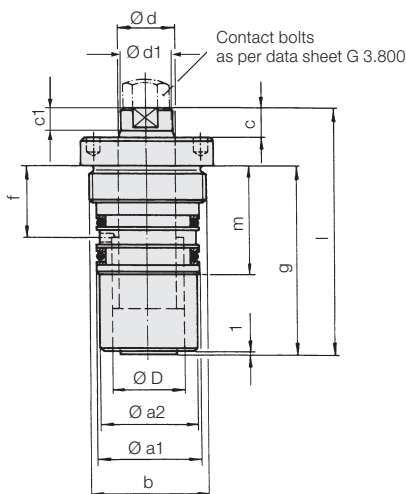

**Application**

Double-acting threaded-body cylinders are used when the return stroke must be effected in a certain time, e.g. with clock-pulse-controlled devices. Of course they can also generate pulling forces.

**Description**

These double-acting cylinders allow a space saving installation into the fixture body and therefore a hosefree oil supply.

The double-wiper protects the piston and enables sealing with very little leakage. Sealing of the cylinders in the fit hole is made by two O-ring/support-ring combinations.

Tightening of the cylinder can be made by a pin-type face spanner as per DIN 3116, so the collar can be immersed into the device, if necessary (see page 2).

**Material**

Piston material: case-hardening steel, hardened.  
Housing: free-cutting steel, black oxide.

**Important notes**

The dimension (depth of bore hole) h has to be strictly observed, as, with regard to the short length we have to dispense with an internal stop.

The insertion chamfer and the bore hole for oil supply have to be rounded in order to secure the seals against damage when screwing in.

The oil supply can be effected at each point outside the fit depth m.

Operating conditions, tolerances and other details see data sheet A 0.100.

		16	20	25	32	40
<b>Piston Ø D</b>	[mm]	16	20	25	32	40
<b>Rod Ø d</b>	[mm]	10	12	16	20	25
Hub ± 1	[mm]	16	20	25	32	40
Force to push at 100 bar	[kN]	2.0	3.1	4.9	8.0	12.6
Force to push at 500 bar	[kN]	10.0	15.7	24.5	40.2	62.8
Force to pull at 100 bar	[kN]	1.2	2.0	2.9	4.9	7.7
Force to pull at 500 bar	[kN]	6.1	10.0	14.5	24.5	38.3
Oil volume / 10 mm stroke extension/retraction	[cm <sup>3</sup> ]	2.0/1.2	3.1/2.0	4.9/2.9	8.0/4.9	12.56/7.7
Ø a 1 f7	[mm]	22	28	35	44	55
Ø a 2	[mm]	21	26	33	42	53
b	[mm]	M26x1.5	M32x1.5	M40x1.5	M50x1.5	M60x1.5
c	[mm]	6	7	7	10	12
Ø d1 x c1	[mm]	9.2x3.7	11.2x5.3	15x5	19x8.6	24x9.1
Ø e H7	[mm]	22	28	35	44	55
f1	[mm]	19	20	25	28	30.5
f2 min.	[mm]	34	35	43	48	51
g	[mm]	48	53	65	72	86
h ± 0.2	[mm]	48	53	65	72	86
i	[mm]	53	62	72	79	93
k ± 0.2	[mm]	8.5	10.5	13.5	15.5	17
l ± 1	[mm]	65	67	82	94	112
m + 1	[mm]	30	31	39	44	47
Ø n	[mm]	31	37	44	54	65
o x depth of thread	[mm]	M6x12	M8x12	M10x15	M12x15	M16x25
Ø p	[mm]	3.2	4.2	5.2	6.2	6.2
r	[mm]	25	30	35	42	50
s min.*	[mm]	8	10	11	13	16
SW	[mm]	8	10	13	17	22
Seating torque	[Nm]	50	100	200	400	650
Weight	[kg]	0.165	0.25	0.5	0.9	1.7
Temperat. up to 100°C	<b>Part no.</b>	<b>1471001</b>	<b>1472001</b>	<b>1473001</b>	<b>1474001</b>	<b>1475001</b>
Temperat. up to 150°C (FKM)	<b>Part no.</b>	<b>1471011</b>	<b>1472011</b>	<b>1473011</b>	<b>1474011</b>	<b>1475011</b>

\* for 500 bar operating pressure and material with 500 N/mm<sup>2</sup> breaking strength

Application example see page 2.

Connection possibilities

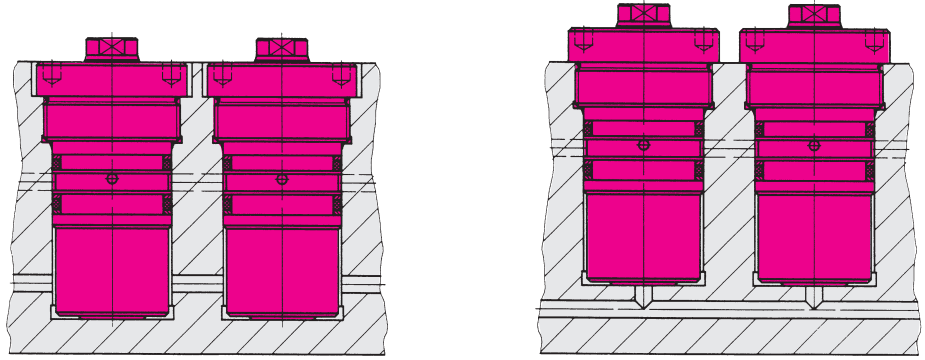

Application example

Double-acting threaded-body cylinders in a multiple clamping bar for a welding fixture (Contact bolt with coupling pin see data sheet G 3.800)

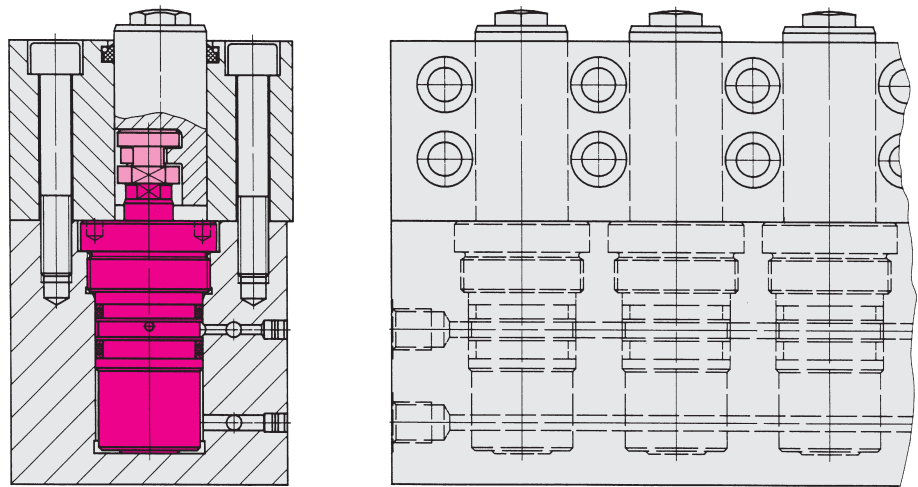

Double-acting threaded-body cylinders as pull-type cylinder for a multiple clamping fixture to mill a wrench flat

