



## Slide Pivot Clamp

compact version, with optional position monitoring,  
 double acting, max. operating pressure 350 bar



### Advantages

- High clamping force, up to 10 kN
- Minimum dimensions
- High efficiency
- Increased rigidity allows compensation of transverse forces at the clamping point
- Unimpeded loading and unloading of the fixture
- Inductive or pneumatic monitoring of the clamping lever available as accessory
- Monitoring of the unclamping position and the usable clamping range is possible
- Clamping lever can be swivelled into small recesses
- Partially immersed mounting of the body
- Oil supply alternatively via fittings or drilled channels
- Long life due to metallic wiper to protect the piston rod

### Function

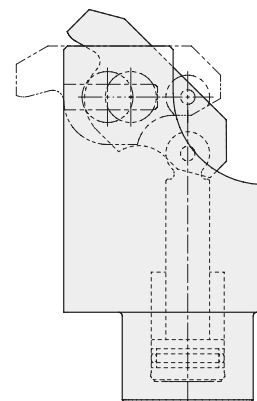

### Description

In the case of the slide pivot clamp the piston force is deviated by 180° by the clamping lever and is available as clamping force with virtually no loss of efficiency. Kinematics of the slide pivot clamp allow sliding back of the clamping lever during unclamping for unimpeded insertion of the workpieces.

Position of the clamping lever can be monitored by inductive proximity switches or pneumatic jets.

The pivot slide clamp can be installed immersed up to the flange surface in a hole of the fixture body or via intermediate plates which are available as an accessory. For both solutions there is the possibility to supply the hydraulic oil not only by fitting connection but also via drilled channels in the fixture body.

### Application

The slide pivot clamp has in relation to its base a very high clamping force. The clamps are particularly suitable for clamping tasks on machines with high performance and reduced space availability on the fixture. The workpieces can be inserted from above without any impediments. A clamping recess a little bit wider than the clamping lever is sufficient as clamping surface. This characteristic indicates their use for clamping of aluminium parts, which are very sensitive against deformation, with correspondingly reduced oil pressure.

### Installation possibilities

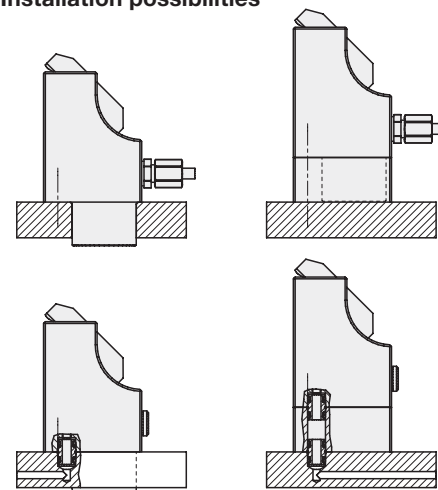

### Important notes

The clamping lever must not be impeded during swivelling movement.

The slots of the sliding pad have to be checked from time to time with regard to contamination by swarf and cleaned, if required.

Operating conditions, tolerances and other data see data sheet A 0.100.

**Metallic wiper  
 standard**

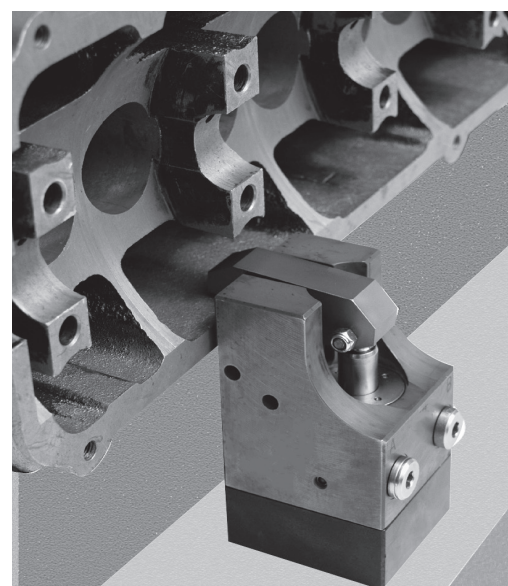

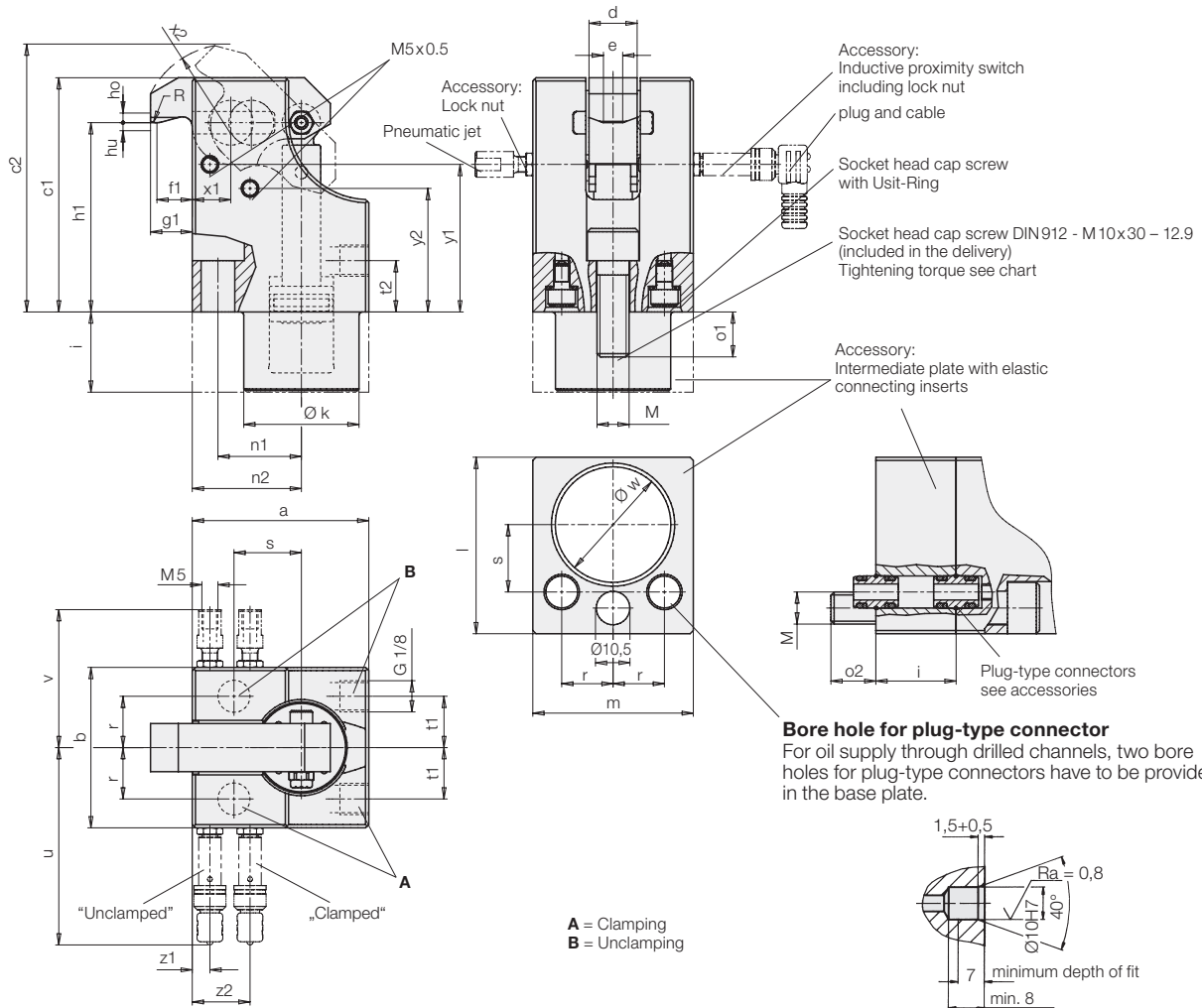

Clamping force $F_{Sp}$ at 350 bar	[kN]	10
Oil volume clamping	[cm <sup>3</sup> ]	6
Oil volume unclamping	[cm <sup>3</sup> ]	4
Max. flow rate	[cm <sup>3</sup> /s]	10
a	[mm]	55
b	[mm]	50
c1 / c2	[mm]	73 / 83.5
d	[mm]	15
e	[mm]	6
f1	[mm]	11
g1	[mm]	13
h1	[mm]	59
ho / hu, upper / lower clamping point	[mm]	3.0 / 2.5
i	[mm]	25
Ø k	[mm]	35.9
l	[mm]	55
m	[mm]	50
M, socket head cap screw DIN912 / seating torque	[Nm]	M10 / 87
n1 / n2	[mm]	26 / 34
o1 / o2	[mm]	14 / 14
r ± 0.02	[mm]	16
R	[mm]	5
s ± 0.02	[mm]	21
t1 / t2	[mm]	16 / 16
u, approx.	[mm]	62
v, approx.	[mm]	43
Ø w + 0.1, mounting hole	[mm]	36
x1 / x2	[mm]	12 / 28
y1 / y2	[mm]	46 / 38.5
z1 / z2	[mm]	5.5 / 18
<b>Part no.</b>		<b>1824040</b>

For manifold mounting, remove socket head cap screws with USIT rings and 2 screw-in plugs G 1/8 in the body.

Accessory	Part no.
Screw plug G 1/8	<b>3610158</b>
Plug-type connector	
Required are: 2 off without or 4 off with intermediate plate	<b>9210132</b>
Induct. proximity switch	<b>3829198</b>
Plug + cable	<b>3829099</b>
Pneumatic jet	<b>3612033</b>
Lock nut	<b>3301803</b>
Intermediate plate for 1824040	<b>3456425</b>
Socket head cap screw DIN912 - M10x55 12.9	<b>3300434</b>

**Technical characteristics for inductive proximity switches**

Operating voltage UB	10 ... 30 V DC
Switching function	Interlock
Output	PNP
Filter body material	Stainless steel
Protection as per DIN 40050	IP 67
Environmental temperature	-25 ... +70 °C
Connection	Connector
LED Function display	Yes
Constant current max.	150 mA
Rated operating distance	0.8 mm
Protected against short circuits	Yes

Article available on request

On request, we will check whether the article is still available.