

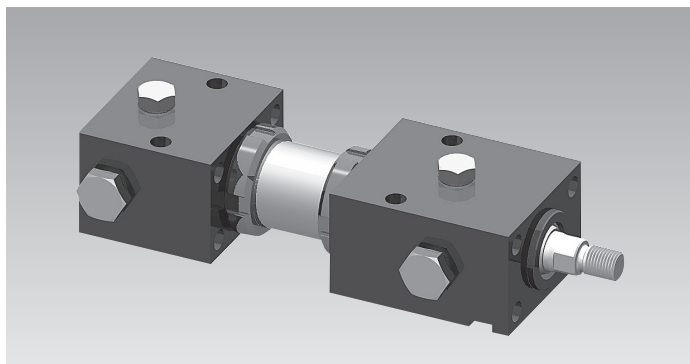

## Hydraulic Block Cylinders

design with tube, optionally with stroke end cushioning and stroke end control, double acting, max operating pressure 250 bar



Hydraulic block cylinder in standard version

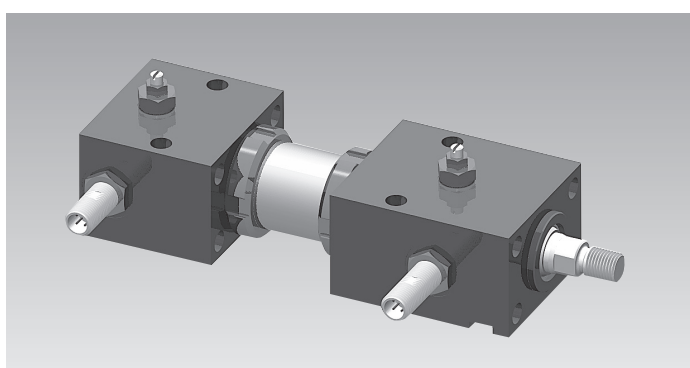

Hydraulic block cylinder with stroke end cushioning and control of the end positions

### Connecting and fixing possibilities

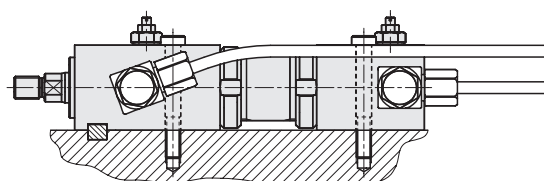

Oil supply through high-pressure hoses or tubes

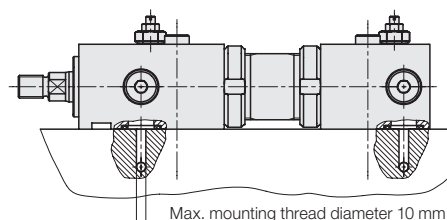

Oil supply through drilled channels

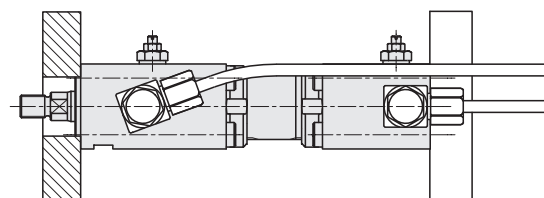

Fixing at the front or at the bottom with oil supply through high-pressure hoses or tubes

### Application

Over years the ROEMHELD block cylinder has proved a building block in hydraulic systems. The hydraulic block cylinder completes this programme by the following characteristics:

- Piston stroke up to 1200 mm
- Installation possibility of high-pressure resistant sensors for the stroke end control
- Adjustable stroke end cushioning available

The application possibilities in machine and apparatus construction are considerably extended, especially in mould construction for operation of core-pullers and slides.

### Description

The hydraulic block cylinder as linear drive combines the advantages of two series

- Hydraulic cylinders with long strokes and optional stroke end cushioning,
- Block cylinders with diverse fixing and oil supply possibilities and optional stroke end control.

The two cylinder heads in block form are connected by a HP tube, in which the piston is guided.

The HP tube and the chromium-plated piston rod material are cut goods, which allows manufacturing of any piston strokes in a very short time. The different connecting and fixing possibilities are shown in the above examples. The hydraulic block cylinder can be delivered with and without adjustable stroke end cushioning.

High-pressure resistant sensors are available for the stroke end control, which are selected according to the cylinder size and temperature (see chart on page 4).

### Important notes

The high-pressure resistant sensors are delivered separately for mounting at place of installation in order to avoid transport damage. Please refer to the installation instructions on page 4.

### Advantages

- Diverse fixing possibilities
- Tenon slot
- Oil supply through fittings or drilled channels with O-ring sealing
- Piston rod hardened and chromium-plated
- Piston rod sealing with minimum leakage
- Standard FKM seals
- Piston stroke up to 1200 mm
- Adjustable stroke end cushioning on request
- Stroke end control can be retrofitted with high-pressure resistant sensors



**Piston rod with external thread**

**View for 1593 up to 1596**

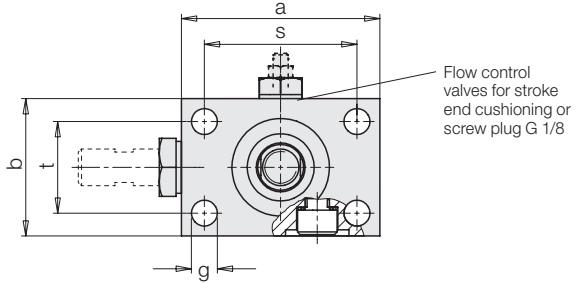
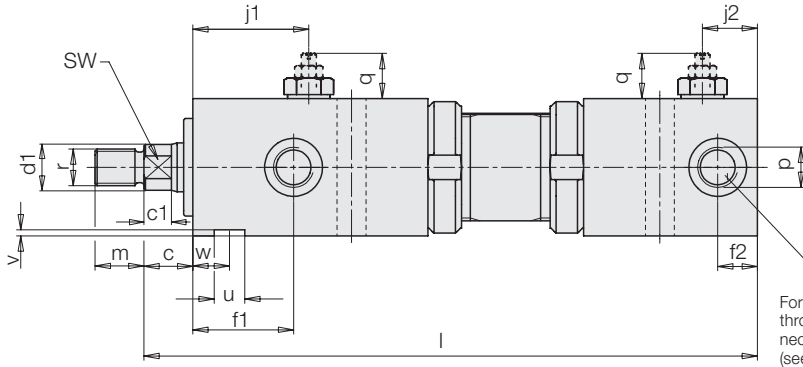

For manifold mounting "oil supply through drilled channels" the connecting threads have to be closed (see screw plug in chart 3)!

**Piston rod with internal thread**

**View for 1597 up to 1598**

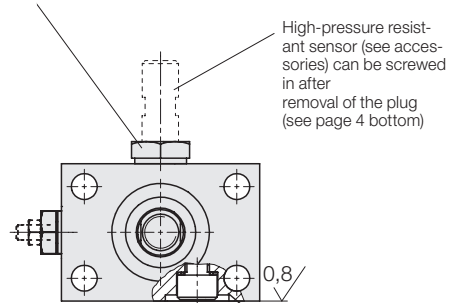
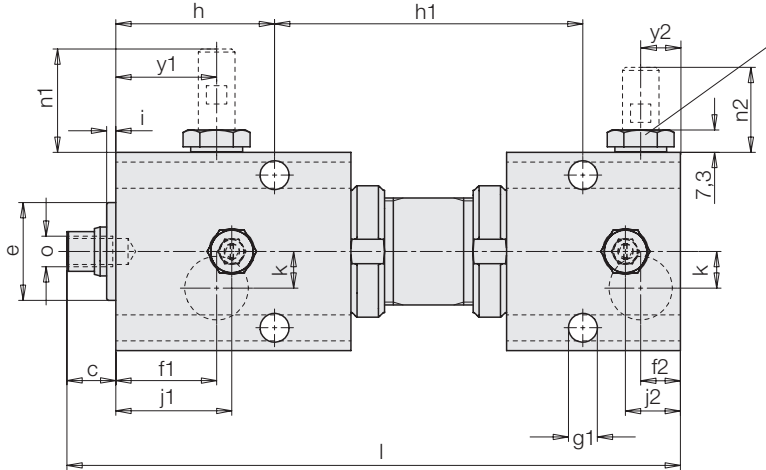

For manifold mounting (see example left-hand side bottom) remove socket head cap screw with sealing and insert O-ring into the counterbore (see accessories)

When fixing with 2 screws (property class 12.9) and a pressure exceeding 100 bar, the cylinder must be backed up in the slot.

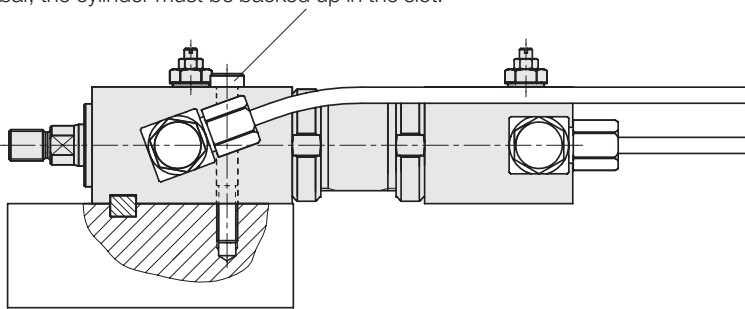

When fixing with 4 screws (property class 12.9) and a pressure exceeding 200 bar, the cylinder must be backed up in the slot.

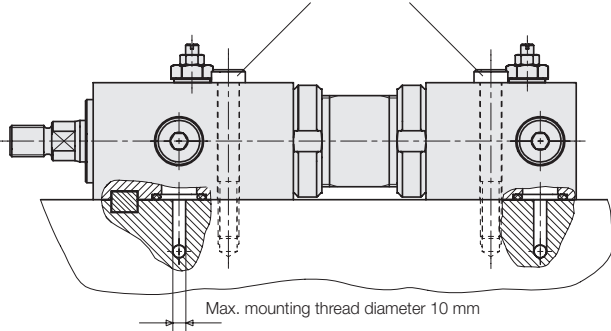

**Admissible transverse force with extended piston rod**

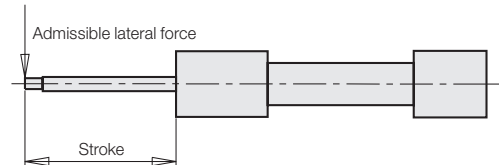
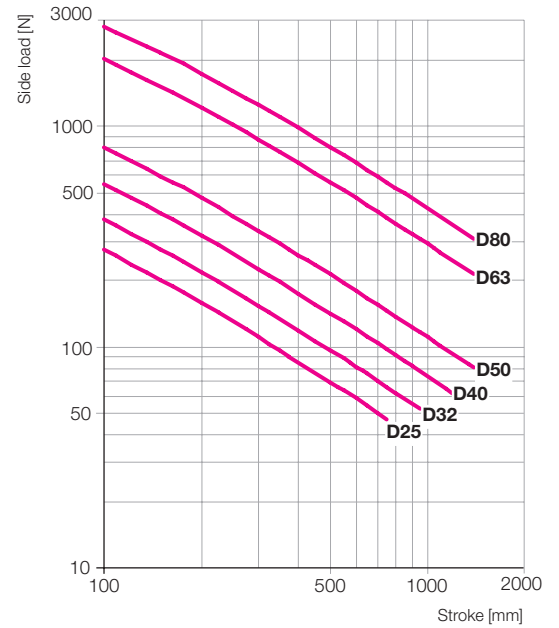



Hydraulic block cylinder (see code for part-nos.)		1593	1594	1595	1596	1597	1598
Piston Ø D	[mm]	25	32	40	50	63	80
Rod Ø d	[mm]	16	20	25	32	40	50
Nominal force at 250 bar	Extending stroke [kN]	12.3	20.1	31.4	49.1	77.9	125.7
	Retracting stroke [kN]	7.25	12.3	19.1	29	46.5	76.6
Piston area	[cm <sup>2</sup> ]	4.9	8.04	12.56	19.63	31.17	50.26
Annulus area	[cm <sup>2</sup> ]	2.89	4.9	7.65	11.59	18.6	30.6
Cushioning stroke	[mm]	16	16	20	25	32	40
L ± 0.75 = desired stroke +	[mm]	111	124	153	166	193	230
a	[mm]	65	75	85	100	125	160
b	[mm]	45	55	63	75	95	120
c	[mm]	16	16	16	18	20	22
Ø d1 x c1	[mm]	15x9	19x8	24x9	31x10	39x12	49x13
Ø e f7	[mm]	32	40	50	60	70	85
f1	[mm]	33	38.5	46	54	66	79
f2	[mm]	13	14	18	21	26	36
Ø g	[mm]	8.5	8.5	10.5	13	17	21
Ø g1 for (MXX)	[mm]	9.5 (M8)	11.5 (M10)	11.5 (M10)	14 (M12)	18 (M16)	22 (M20)
h	[mm]	52	56	64.5	74	94	105
h1 = desired stroke +	[mm]	11	21	38.5	33	23	42.5
i	[mm]	3	4	4	4	4	5
j1	[mm]	38	45	57	64	58	72
j2	[mm]	18	20	26.5	31	18	26
k	[mm]	12	14.5	16	20	30	32
m	[mm]	16	18	22	28	36	45
n1	[mm]	34	31	29	47	31	45
n2	[mm]	28	25	23	39.5	22	34.5
o x depth of thread (internal thread)	[mm]	M10x15	M12x15	M16x25	M20x30	M27x40	M30x40
p		G 1/4	G 1/4	G 1/4	G 1/4	G 1/2	G 1/2
q	[mm]	15	14	14	12.5	11	11
r (external thread)	[mm]	M12x1.25	M14x1.5	M16x1.5	M20x1.5	M27x2	M33x2
SW	[mm]	13	17	22	27	36	46
s	[mm]	50	58	66	80	99	124
t	[mm]	30	38	44	55	69	84
u H11	[mm]	10	12	12	14	20	22
v	[mm]	2	3	3	3	4	5
w	[mm]	12	16	24	32	35	50
y1	[mm]	33	38.5	46	50.5	60.5	69
y2	[mm]	13	14	18	16.5	20.5	21
minimum stroke* ± 1.5	[mm]	70	70	60	70	80	80
minimum stroke** ± 1.5	[mm]	130	140	150	170	190	210
maximum stroke ± 1.5	[mm]	750	950	1200	1200	1200	1200

**Accessories**

Part no. high-pressure resistant sensor (s. page 4)	<b>3829 180</b>	<b>3829 180</b>	<b>3829 180</b>	<b>3829 030</b>	<b>3829 180</b>	<b>3829 030</b>
Dimensions of O-ring for manifold mounting [mm]	15.54x2.62	15.54x2.62	15.54x2.62	15.54x2.62	18.72x2.62	18.72x2.62
Part no. O-ring (FKM)	<b>3000 103</b>	<b>3000 103</b>	<b>3000 103</b>	<b>3000 103</b>	<b>3001 061</b>	<b>3001 061</b>
Part no. Screw plug with hexagon socket	<b>3300 821</b>	<b>3300 821</b>	<b>3300 821</b>	<b>3300 821</b>	<b>3610 045</b>	<b>3610 045</b>

**Code for part numbers**

159X X X XXXX

0XXX = stroke in mm up to 999 mm } min. and max. strokes  
1XXX = stroke in 1000 mm and over } see at the end of the chart

1 = without cushioning  
3 = with cushioning

1 = piston rod with exterior thread  
2 = piston rod with interior thread

3 = piston-Ø D 25 mm  
4 = piston-Ø D 32 mm  
5 = piston-Ø D 40 mm  
6 = piston-Ø D 50 mm  
7 = piston-Ø D 63 mm  
8 = piston-Ø D 80 mm

**On request, we will check whether the article is still available.**

**Order example:**

- Hydraulic block cylinder Ø 40 x 755 stroke without cushioning and piston rod with interior thread : **1595 21 0755**
- Hydraulic block cylinder Ø 63 x 1015 stroke with cushioning and piston rod with exterior thread : **1597 13 1015**

- \* minimum stroke with fixing at the broad side
- \*\* minimum stroke with fixing at the front by flange

**Limit values for stroke and operating pressures at buckling load (safety against buckling = 3.5)**

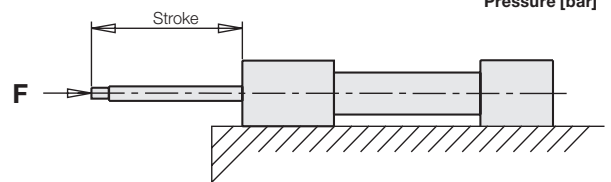
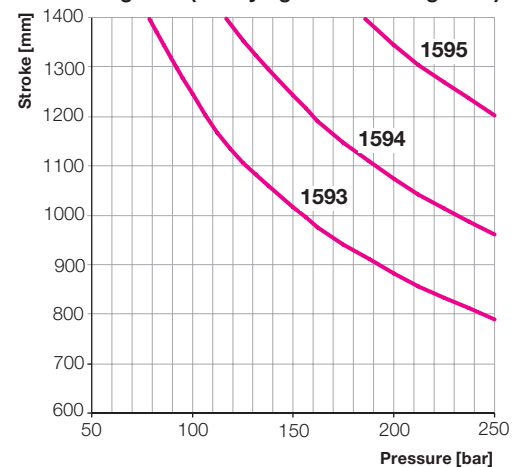



For cylinders:

1593XXX  
1594XXX  
1595XXX  
1597XXX

1596XXX  
1598XXX

General and technical characteristics

Environmental temperature	°C	-25...+80	-25...+120	-25...+80	-25...+120
Rated operating distance Sn	mm	1.5	1.5	1.5	1.5
Secured operating distance Sa	mm	0...1.2	0...1.2	0...1.2	0...1.2
Repeatability	%	≤ 5	≤ 5	≤ 5	≤ 5
Hysteresis	%	≤ 15	≤ 15	≤ 15	≤ 15
Dimensions DxT	mm	M12x1x56	M12x1x56	M12x1x78	M12x1x78
Material of the body		1.4104	1.4104	1.4104	1.4104
Material of sensing face		EP (Duroplast)	Ceramics	EP (Duroplast)	Ceramics
Code class	IP54	68	68	68	68
Connection type		Plug S4	Plug S4	Plug S4	Plug S4
<b>Electrical characteristics</b>					
Voltage		DC	DC	DC	DC
Wiring		3 wires	3 wires	3 wires	3 wires
Switching function		interlock	interlock	interlock	interlock
Output signal		pnp	pnp	pnp	pnp
Rated operating voltage	V	24 DC	24 DC	24 DC	24 DC
Rated operating current	mA	200	200	200	200
Operating voltage	V	10...30 DC	10...30 DC	10...30 DC	10...30 DC
Ripple	%	≤ 15	≤ 15	≤ 15	≤ 15
Switching frequency	Hz	2000	400	1000	400
No-load current	mA	≤ 10/≤ 2	≤ 8	≤ 10/≤ 1	≤ 8
Voltage drop	V	≤ 1.5/-	≤ 2.5	≤ 1.5/-	≤ 2.5
Short circuit protection		yes	yes	yes	yes
Protection against reverse battery		yes	yes	yes	yes
<b>Part no. sensor</b> (with mounted seals)		<b>3829180</b>	<b>3829228</b>	<b>3829030</b>	<b>3829227</b>

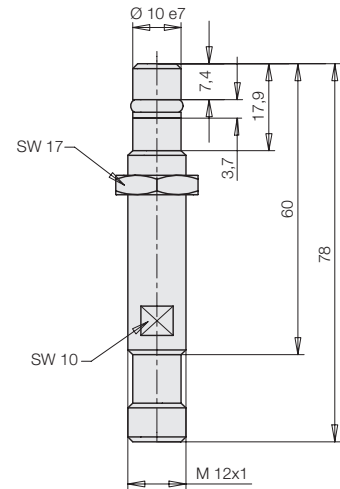
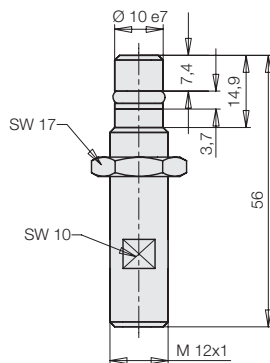
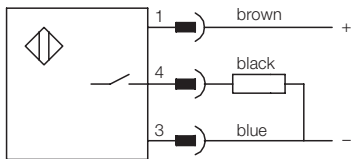

Mounting and setting of the sensors

Front sensor:

- Extend piston rod completely
  - Carefully screw in the sensor to the stop at the piston.  
Turn back the sensor:
- | Rotation | Switching point before the final position |
|----------|-------------------------------------------|
| 1/4      | approx. 4 mm                              |
| 1 1/4    | approx. 1 mm                              |
- Lock the sensor in this position by means of a nut
  - Wire the switch electrically and check the function

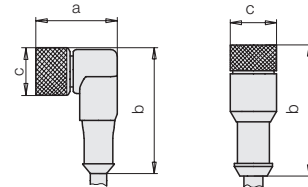
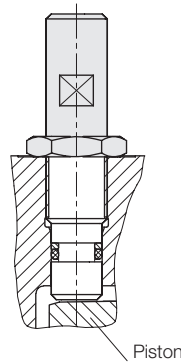

LED: Operating voltage (green)  
Function display (yellow)

Rear sensor:

- Retract completely the piston rod  
(Further steps see front sensor)

Accessories for sensors

Accessories for sensors	a	b	c	Cable length [m]	Code class	Environmental temperature	LED	Part no.
Plug-type connector pnp M12, knee-type	27	38	14.5	3	IP68	-25...+80 °C	yes	<b>3829049</b>
Plug-type connector pnp M12, straight	-	44	14.5	5	IP68	-40...+90 °C	no	<b>3829078</b>
Plug-type connector pnp M12, knee-type	27	38	14.5	5	IP68	-20...+105 °C	no	<b>3829230</b>
Plug-type connector pnp M12, straight	-	44	14.5	5	IP68	-40...+105 °C	no	<b>3829229</b>