

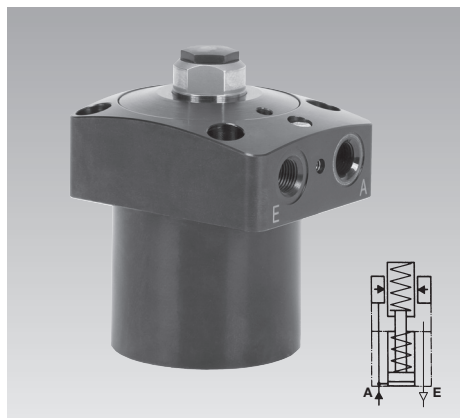

Work Supports

Top flange type, metallic wiper edge or TF1 wiper single acting, max. operating pressure 70 bar



Advantages

- Load force up to 25 kN
- Space-saving version
- 2 sizes available
- Alternatively metallic wiper edge or TF1 wiper
- Contact force of the support plunger selectable
- Inner parts protected against corrosion
- Alternatively pipe thread or drilled channels
- Flow control valve available as accessory
- Connection for venting and positive air pressure protection
- Mounting position: any
- Connection of positive air pressure protection up to 4 bar is possible

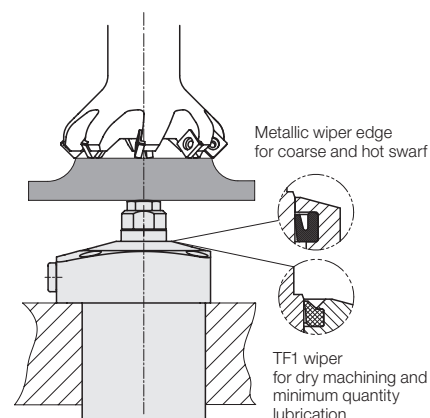

Application

Hydraulic work supports are used to provide a self-adjusting rest for workpieces and avoid their vibration and deflection under machining loads. This series offers very high support forces already at 70 bar and can directly be connected to the low-pressure hydraulic of the machine tool. Due to their compact design they can be arranged in a very limited space. Oil supply is made through drilled channels or pipe thread.

Description

The support plunger is hydraulically extended by a small piston and contacts the workpiece with spring force. The contact spring can be easily exchanged.

Locking of the support plunger is made through the slotted clamping sleeve and by means of a ring-shaped conical hydraulic piston where the locking force is transmitted by a low-friction ball shell.

Unlocking and retracting of the support plunger is made by spring force.

Positive air pressure connection

To guarantee functioning of the work supports, a vent port is imperative. No liquids may enter the end of the bore hole (see also data sheet G 0.110 „Venting of the spring area“).

It is recommended to connect positive air pressure protection. While locking the support plunger, the positive air pressure must not exceed 4 bar. If the support plunger is not locked, the positive air pressure must be reduced to a maximum of 0.2 bar.

The positive air pressure connection must be free of oil and water.

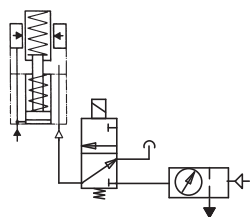

Connection of positive air pressure protection

Installation and connecting possibilities

Drilled channels

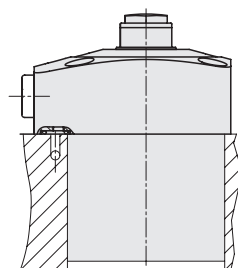

Pipe thread

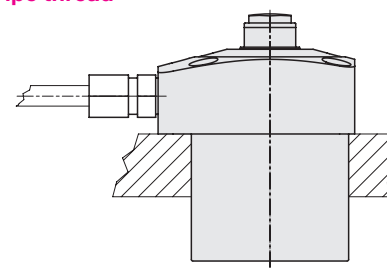

Clamping / load force as a function of the operating pressure

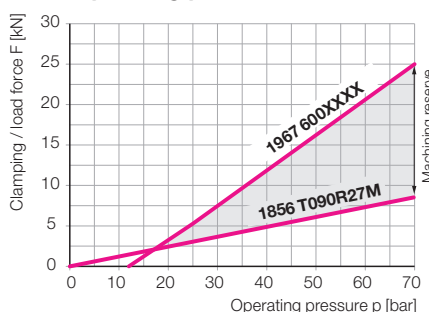

Combination with clamping elements

With this combination, clamping and machining forces will add up:

$$\begin{aligned} &\text{Clamping force} \\ &+ \text{max. machining force} \\ &= \text{minimum support force} \times \text{safety factor} \end{aligned}$$

Rough calculation from practice:
Required support force $\geq 2 \times$ clamping force

To increase the safety, a support force as high as possible should be achieved by

- using a larger work support
- utilising the max. operating pressure
- using a smaller clamping element or reducing the clamping pressure

Important notes

Work supports are not suitable to compensate side loads. The support plunger must not be stressed by tensile load.

The admissible load force is valid for static or dynamic load. Machining forces can generate vibrations, whose amplitude exceeds far an average value, and this can cause yielding of the support plunger.

Operating conditions, tolerances and other data see data sheet A 0.100

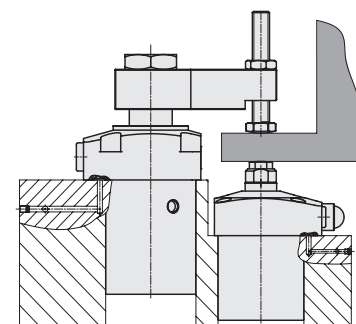

Example

Work support 1967 600XXXX
max. load force at 70 bar 25.0 kN
and
swing clamp 1856 T090R27M
as per data sheet B 1.8500
– Effective clamping force at 70 bar 8.3 kN
= Reserve for machining force 16.7 kN

Dimensions

Technical data • Accessories

Accessory
Flow control valve
2957209
can only be used for
connection via drilled
channels

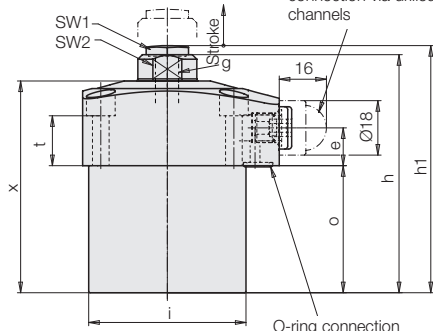

Important note
Both O-rings must be inserted also
for pipe thread connection.

O-ring connection
2 x O-ring 7x1.5
included in the delivery

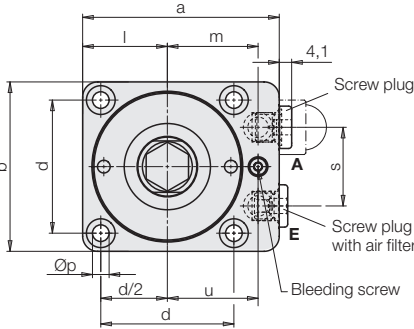

A = hydraulics G 1/8
E = venting or positive air pressure connection G 1/8

Connecting scheme

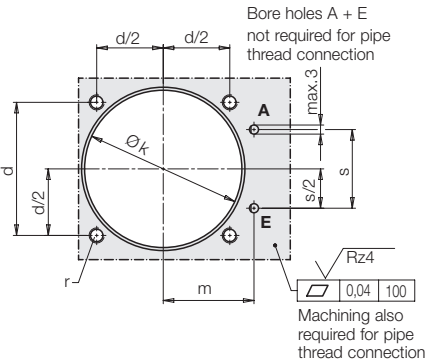

Dimensions for self-made contact bolts

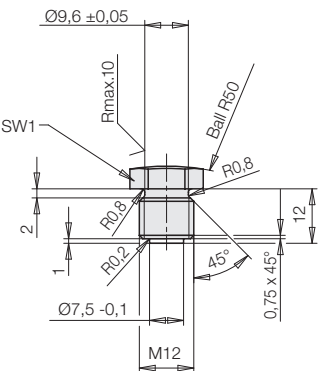

Max. load force at 70 bar	[kN]	15.5	25
Load force at p (bar)	[kN]	0.272 x p-3.54	0.439 x p-5.70
Support plunger ØD	[mm]	20	22
Stroke	[mm]	12	14
Required oil per stroke	[cm ³]	3.5	5
Admissible flow rate	[cm ³ /s]	25	25
Recommended minimum pressure	[bar]	25	25
Max. pressure in the return line	[bar]	1	1
Elastic deformation with load and 70 bar	[µm/kN]	2.5	2.5
Operating temperature	[°C]	0... 70	0... 70
a	[mm]	65	75
b	[mm]	56	65
d	[mm]	44	52
e	[mm]	12.5	12.5
g x depth	[mm]	M 12x12	M 12x12
h	[mm]	78.7	97
h1	[mm]	81.7	102
Øi	[mm]	52 - 0.2	60 - 0.2
Øk	[mm]	52 + 0.3/+0.1	60 + 0.3/+0.1
l	[mm]	28	32.5
m	[mm]	30	33.5
o	[mm]	42	57
Øp	[mm]	5.5	6.5
r		M5	M6
Tightening torque	[Nm]	5.9	10
s	[mm]	26	30
t	[mm]	16.5	15.9
u	[mm]	30	36
x	[mm]	70	87
SW1	[mm]	14	14
SW2	[mm]	17	19

Wiper and metallic wiper edge

		M	M
Plunger contact force min./max.	[N]	4/14	4/12
Part no.		1967500M112	1967600M114
Plunger contact force min./max.	[N]	11/17	10/15
Part no.		1967500M312	1967600M314
Plunger contact force min./max.	[N]	12/28	16/28
Part no.		1967500M512	1967600M514
TF1 wiper		B	B
Plunger contact force min./max.	[N]	11/17	10/15
Part no.		1967500B312	1967600B314
Plunger contact force min./max.	[N]	12/28	16/28
Part no.		1967500B512	1967600B514

Accessory

Flow control valve G 1/8	2957209	2957209
Screw plug G 1/8	3610158	3610158

Connecting possibilities (see page 1)

1. Pipe thread

1.1 Dry environment

Port E: Screw plug with air filter

1.2 Wet environment

Port E: Fitting G1/8 with pipe laid in a dry place

2. Drilled channels

2.1 Wet environment

Port A: Screw plug G1/8 or flow control valve
2957209 (accessory)

Port E: Screw plug with air filter

2.2 Wet environment

Port A: see 2.1

Port E: Screw plug G 1/8

3610158 (accessory)

Adm. load force F as a function of the operating pressure p

