



**Threaded-Coupling Elements**  
max. operating pressure 500 bar



**Application**

Compared to other coupling elements the threaded coupling elements are very compact devices.

If the slide movement of the workpiece carrier is to be used or if a fixture is to be connected to the base plate without lines, the threaded nipple and the coupling mechanisms can be directly screwed into the parts which are to be connected. The coupling mechanisms have the advantage that they are flush-faced in uncoupled mode. Flange-type housings are available to simplify the manufacture of the fixture mounting hole contours. In cramped conditions it is possible to make and install the flange-type housing retrospectively.

The fixture bodies which are to take up the coupling parts have to be guided 2–3 mm in a parallel motion before they are coupled.

The axial forces which arise during the pressure build-up in coupled mode (see diagram) have to be absorbed outside the coupling parts.

The long coupling nipple provided with a preloaded valve (PV) can be installed in the return or unclamping line of a clamping fixture. The valve limits a possible pressure build up in uncoupled (static) condition to approx. 5 bar. The preloaded valve is not effective in coupled condition.

**Manifold-mounting hole**

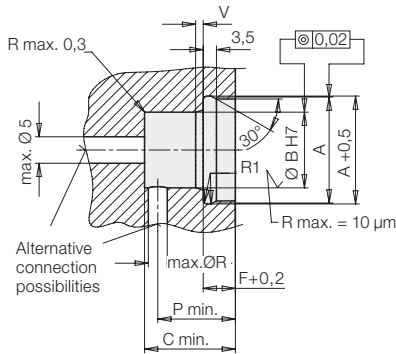

**Threaded nipple**

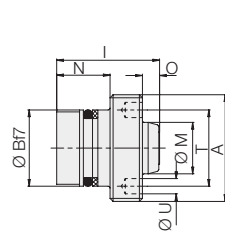

**Coupling mechanism**

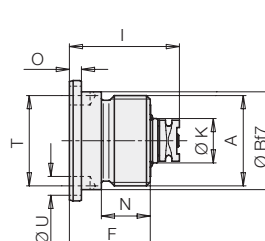

**Manifold-mounting hole**

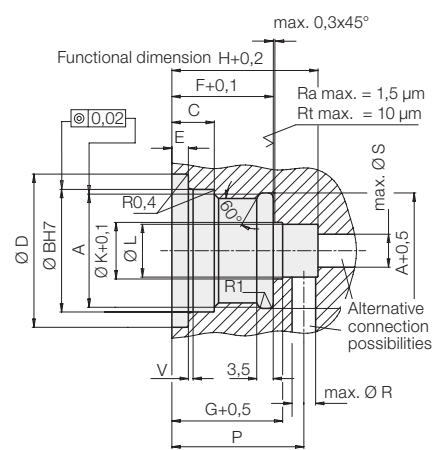

Element		Coupling mechanism	Treaded nipple	Treaded nipple with VS	Coupling mechanism	Treaded nipple with VS	Treaded nipple
NW		3	3	3	5	5	5
max. operating pressure	[bar]	350	350	350	500	500	500
max. flow rate	[l/min]	8	8	8	12	12	12
A	[mm]	M 20 x 1,5	M 24 x 1,5	M 24 x 1,5	M 24 x 1,5	M 28 x 1	M 28 x 1
Ø B	[mm]	22	20	20	26	20	20
C	[mm]	3,5	27	30	9	30	24
Ø D	[mm]	–	–	–	32,5	–	–
E	[mm]	–	–	–	3,5	–	–
F	[mm]	21,5	10	10	21,5	8,5	8,5
G	[mm]	23,5	–	–	23,5	–	–
H	[mm]	31	–	–	31	–	–
I	[mm]	29,3	29,5	34	29,3	32	27
Ø K	[mm]	12	–	–	12	–	–
Ø L	[mm]	11,2	–	–	11,2	–	–
Ø M	[mm]	–	9,8	9,8	–	13,5	13,5
N	[mm]	18,5	15	19,5	13	19	14
O	[mm]	–	4,5	4,5	3,2	4,5	4,5
P	[mm]	28	21	25	28	20,5	20,5
Ø R	[mm]	5	5	5	5	5	5
Ø S	[mm]	7	7	7	7	7	7
T	[mm]	16	17	17	24	20	20
Ø U	[mm]	3	3,5	3,5	5	4,3	4,3
V		–	2 x 15°	2 x 15°	1 x 15°	2 x 15°	2 x 15°
axial coupling force against pressure per coupling point	[N]		F = 7,9 x p [bar]			F = 15,4 x p [bar]	
axial coupling force at 0 bar	[N]	60	60	60	90	90	90
axial positioning tolerance	[mm]	+ 0,5	+ 0,5	+ 0,5	+ 0,5	+ 0,5	+ 0,5
radial positioning tolerance	[mm]	± 0,1	± 0,1	± 0,1	± 0,2	± 0,2	± 0,2
Angular deviation		± 1°	± 1°	± 1°	± 1°	± 1°	± 1°
Coupling stroke	[mm]	4,5	4,5	4,5	4,5	4,5	4,5
Seating torque	[Nm]	37	40	40	40	45	45
<b>Part no.</b>							
coupling against system press.		<b>0460725</b>	<b>0460727</b>	–	<b>0460735</b>	–	<b>0460638</b>
depressurised coupling		<b>0460730</b>	<b>0460731</b>	<b>0460728</b>	<b>0460736</b>	<b>0460637</b>	<b>0460740</b>
<b>Special steel version</b>							
depressurised coupling		–	–	–	<b>0460763</b>	–	–
<b>Screw-in tool</b>		<b>2010900</b>	<b>2010900</b>	<b>2010900</b>	<b>2010901</b>	<b>2010901</b>	<b>2010901</b>

Depending on the version the coupling elements can either be coupled in energized or in deenergized mode only.

The operating mode depends on the type of sealing elements which are used and can be taken from the table above.

The max. positioning tolerances in axial and radial direction are indicated in the above table.

To transmit compressed air and vacuum use only the coupling elements for “depressurised coupling”.

**The sealing areas at the side of the coupling elements have to be cleaned before coupling, to ensure the connection in coupled mode. We recommend to wash the elements and finally clean them with compressed air. Protection covers should be used as far as possible.**

**Previous cleaning of the even sealing areas is possible by means of rubber wipers.**

# Technical data Accessory

## Accessory flange-type housing

### Mounting dimensions

If it is not required that the housing is flush fitting with the pallet, the diam.  $D + 0.2$  can be omitted.

The depth dimensions are then shortened by dimension F.

Usable for	0460735	0460725	
	0460736	0460730	
A	[mm]	43	30
B	[mm]	23	20
$\varnothing C H7$	[mm]	32	25
$\varnothing D + 0,2$	[mm]	65	50
E	[mm]	38	38
$F + 0,05$	[mm]	15	12
G min.	[mm]	35	34
H	[mm]	12	10
K	[mm]	18	16
L	[mm]	M 8	M 6
M		3 x 15°	3 x 15°
$\varnothing N \text{ max.}$	[mm]	6	5
$\varnothing O$	[mm]	7	7
R	[mm]	60	42
S	[mm]	40	32

**Part no. (housing)**      **0460654**    **0460655**

**Seal kits for connecting housing**      **0131994**    **0131995**

### Flange-type housing

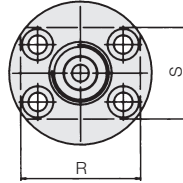
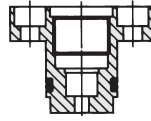

### Manifold-mounting hole

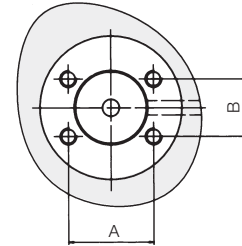
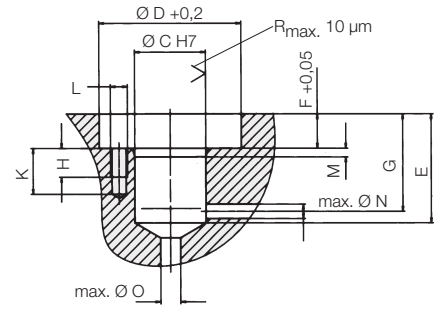

In cramped installation conditions the housing can be machined according to dimensions R and S.

### $\Delta p$ -Q characteristic line for cinematic viscosity

from  $53 \times 10^{-6} \text{ m}^2/\text{s}$  (HLP 22 at 20 °C)

