

Pressure Reducing Valve

Poppet valve without overpressure function

max. operating pressure 500 bar

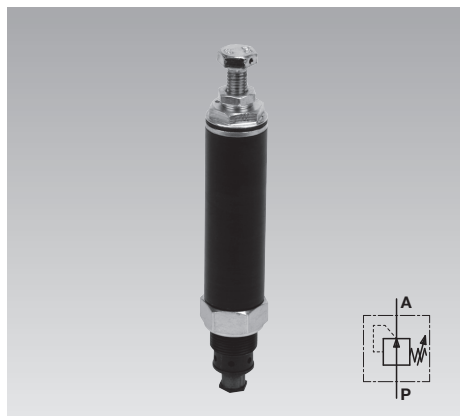

Advantages

- Optimisation of the clamping force of individual cylinders or subassemblies
- Pressure limitation to the admissible operating pressure of individual cylinders or subassemblies.
- Automatic readjustment in case of pressure drop
- No leakage oil port required
- Can be used in uncoupled clamping systems e.g. on clamping pallets
- Big adjusting range
- Possibility to lead
- Different connecting possibilities

Low pressure

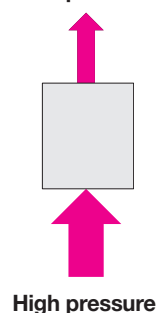

High pressure

Definition

Pressure reducing valves keep the outlet pressure constant, also in case of a changeable, but always higher inlet pressure.

This version without overpressure function cannot compensate a pressure increase of the outlet pressure that exceeds the set pressure (see important notes).

Application

In hydraulic clamping systems, it is often necessary to pressurise single clamping elements or groups of clamping elements with reduced pressure.

This pressure reducing valve without overpressure function is especially suitable for clamping systems which will be uncoupled from the pressure generator, e.g. pallets, because an additional leakage oil line is not available.

Limits of application

This pressure reducing valve can only be used in static clamping systems. The connected clamping elements must be leakage-free.

Important notes!

An increasing pressure cannot be compensated at the outlet side due to the missing overpressure function. Causes for a pressure increase can be:

- Temperature increase (approx. 10 bar per 1 °C)
- Force increase acts on the clamping cylinder
- Damage of the valve seat by swarf

Remedy: Installation of an additional safety valve on the outlet side that is set 10% higher than the pressure reducing valve (see application example).

The outlet pressure can be set and controlled by means of a pressure gauge.

Thus, also the required sealing of the system is monitored.

Pressure adjustment and pressure changes should only be made with simultaneous pressure gauge control.

In the case of incorrect pressure setting, there may be a risk of injury due to overload of the connected elements.

Function

Below the set outlet pressure, the hydraulic oil flows unhindered from P to A. In case of a pressure increase the set spring force is overcome and a check valve cuts off the flow hermetically sealed. Thus, a further pressure increase is avoided, also in case of increasing inlet pressure p. In case of a pressure drop, e.g. because of a leakage at a cylinder, the check valve will be opened by a strong spring against the existing inlet pressure p. Hydraulic oil can continue flowing until the set outlet pressure is obtained.

Increasing outlet pressure, e.g. due to temperature rise cannot be compensated by this pressure reducing valve (see important notes).

A return flow from A to P is only possible if the inlet pressure p drops below the set outlet pressure.

Connecting possibilities

Screw-in valve

Pipe thread

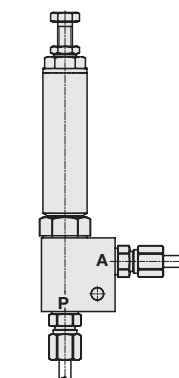
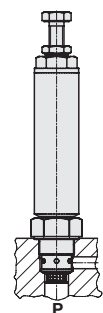

Manifold-mounting connection

Manifold mounting or pipe thread

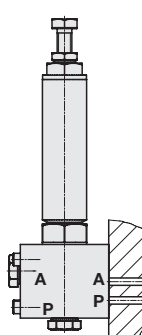
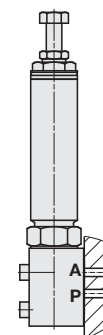

Maximum flow rate

The maximum volume flow rate depends on the selected adjustment range of the outlet pressure (see table on page 2).

If the flow rate of the pump is higher, a flow control valve has to be installed in front of the pressure reducing valve.

To guarantee perfect functioning of the pressure reducing valves, flow control valves and sequence valves must always be installed in front of the pressure reducing valve in the shown sequence.

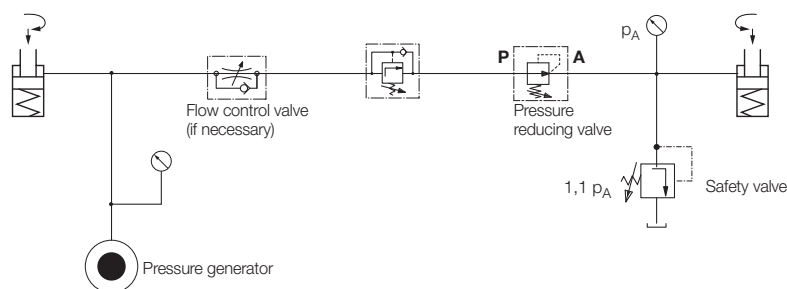

Pressure reducing valves with overpressure function see data sheet C 2.9534.

Technical data

Type	2-way ball-type poppet valve
Mounting position	any
Max. operating pressure (inlet pressure)	500 bar
Adjustment range (outlet pressure)	see part no.
Max. flow rate	see part no.
Max. return pressure	20 bar
p - Q characteristic curve	see diagram
Hydraulic oil	HLP as per DIN 51524
Viscosity class	ISO VG 10...68 as per DIN 51519
Viscosity range	10...500 mm ² /s (recommendation)
Purity class	20 / 17 / 13 as per ISO 4406
Oil temperature	-25...+80 °C
Environmental temperature	-40...+80 °C

Δp - Q characteristic curves (P → A and A → P)

(with open valve, if p_D is smaller than p_A)

Test medium viscosity: 50 mm²/s (cSt)

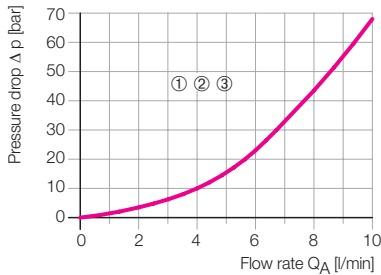

Minimum set pressure p_A min.

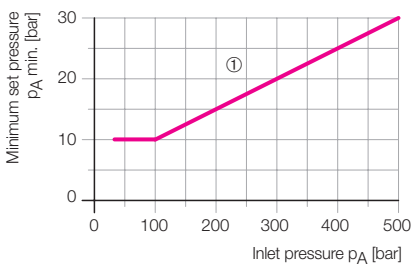

Max. flow rate

as a function of the set outlet pressure p_A

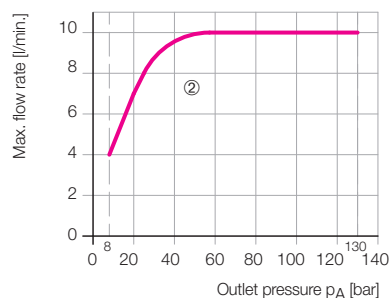

Screw-in valve ① + ②

Weight: approx. 0.7 kg

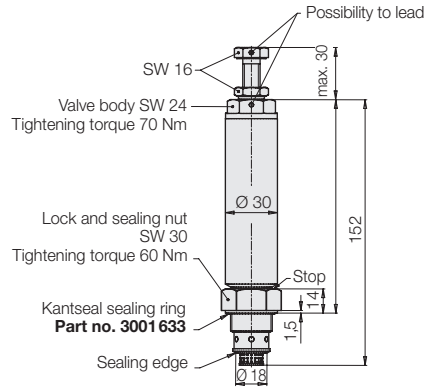

Screw-in valve, short design ③

Weight: approx. 0,5 kg

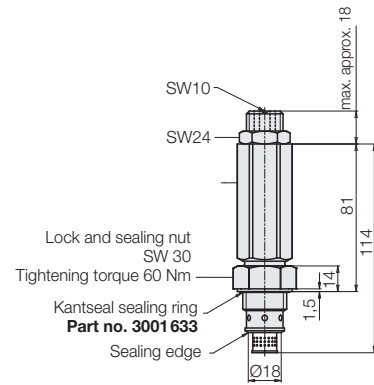

Porting details

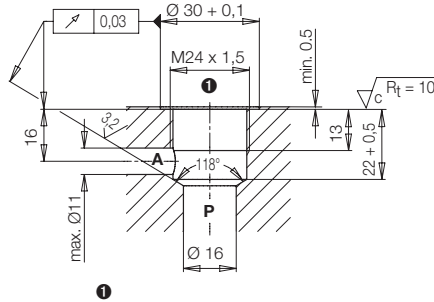

Installation note

1. Before screwing in, turn back lock and sealing nut up to the stop.
 2. Screw in valve body and tighten by 70 Nm. Sealing is made metalically on the counterbore of 118°.
 3. Tighten the lock and sealing nut by 60 Nm. Sealing is made by the Kantseal sealing ring on the counterbore diameter of 30 mm. The sealing ring is included in the delivery.
- Disassembly is made in reverse sequence.

Possible drop of the outlet pressure Δp_A before starting the setting function

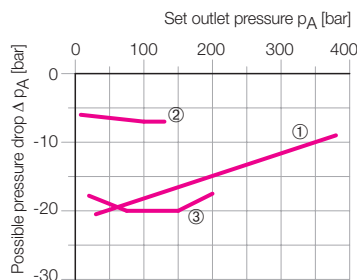

Technical data Dimensions

Type	Part no.	Part no.	Part no.
①	2953 111	2953 114	2953 110
②	2953 112	2953 117	2953 116
③	2953 121	2953 123	2953 122
Connecting block without valve	0353 438	0353 439	0353 440

Pipe thread

Weight: approx. 1.3 kg ①+②
approx. 1.1 kg ③

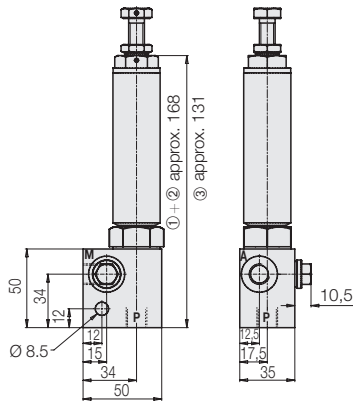

Ports **A**, **P** and **M** = G 1/4

M = pressure gauge connection

Manifold-mounting connection

Weight: approx. 1.1 kg ①+②
approx. 0.9 kg ③

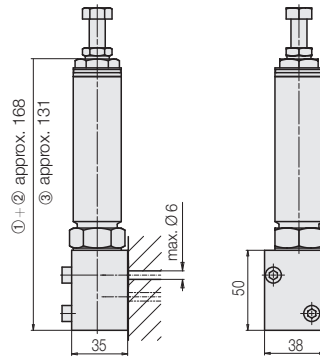

Manifold mounting or pipe thread

Weight: approx. 1.7 kg ①+②
approx. 1.5 kg ③

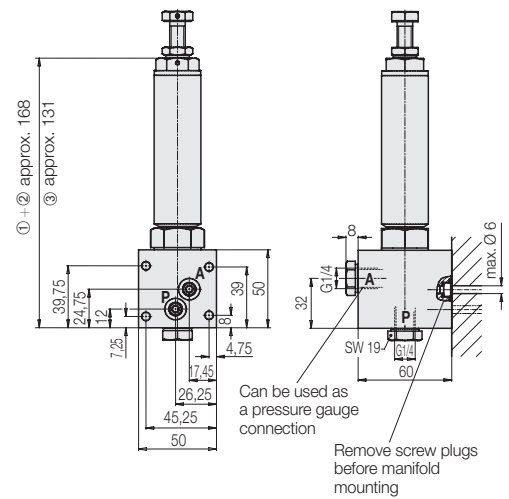

Connecting scheme

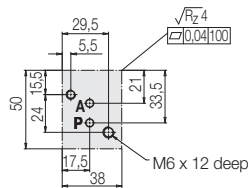

Included in our delivery:

O-rings 7.65 x 1.78

Part no. 3000654

Screws M6 x 45 DIN 912-8.8

Part no. 3300231

Tightening torque 10 Nm

Connecting scheme

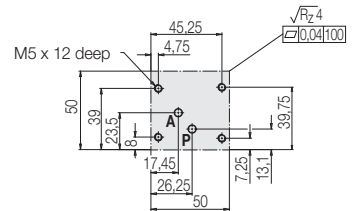

Manifold-mounting connection with hole pattern as per DIN 24340 form A 6, CETOP 4.2-4.3, ISO 4401

O-ring 10x2

Part no. 3001078

(included in the delivery)

4 screws M5x70 DIN 912-12.9

Part no. 3300310

(not included in the delivery)

Tightening torque 10 Nm