

Pipe Couplings

with pipe connection or tapped hole made of steel
nominal diameter 6 – 28, max. operating pressure 160 – 420 bar

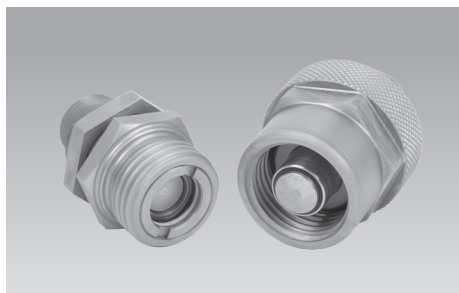

Advantages

- Particularly sturdy design
- Minimum fluid loss during coupling and uncoupling
- Subsequent bleeding of the system unnecessary

Materials

Steel, zinc/nickel coated
Back-up ring: PTFE
Seal: NBR + PUR

Operating temperature

-20 °C to +80 °C

Application

- Construction machines
- Agricultural machines
- Railway engineering
- Offshore industry
- Robotics
- Special vehicles and others

Description

The pipe couplings are screw coupling with shut-off on both sides. The valves in the fixed and loose halves open and close automatically during the coupling process.

To ensure proper functioning, the two halves must be screwed together up to the stop of the connecting thread.

This coupling reduces the fluid loss during coupling and uncoupling to a minimum.

Due to the screw closure it is possible to couple against a residual pressure. The coupling of coupling halves under full operating pressure must be avoided, otherwise the seals will be damaged.

Important notes

Storage: pipe couplings can be stored for 6 months under storage conditions as per DIN 7716.

Accessories

- Dust protection with flap
- Wall bracket
- Lock nut
- Screw plug

Size	Flow cross section [mm ²]	Nominal pressure				Coupling against pressure			
		Coupling coupled [bar]	Coupling uncoupled		Couple		Uncouple		
			Fixed half [bar]	Loose half [bar]	with wrench [bar]	without wrench [bar]	with wrench [bar]	without wrench [bar]	
2	55	420	420	300	100	50	100	100	
3	105	300	300	160	100	50	100	50	
4	155	300	300	200	80	–	100	–	
6	285	300	300	200	50	–	100	–	
8	620	420	420	420	30	–	30	–	

In the case of standard threaded connections, the maximum admissible operating pressure of the connection must be taken into account when determining the operating pressure.

Flow resistances

Test medium: hydraulic oil, depending on viscosity

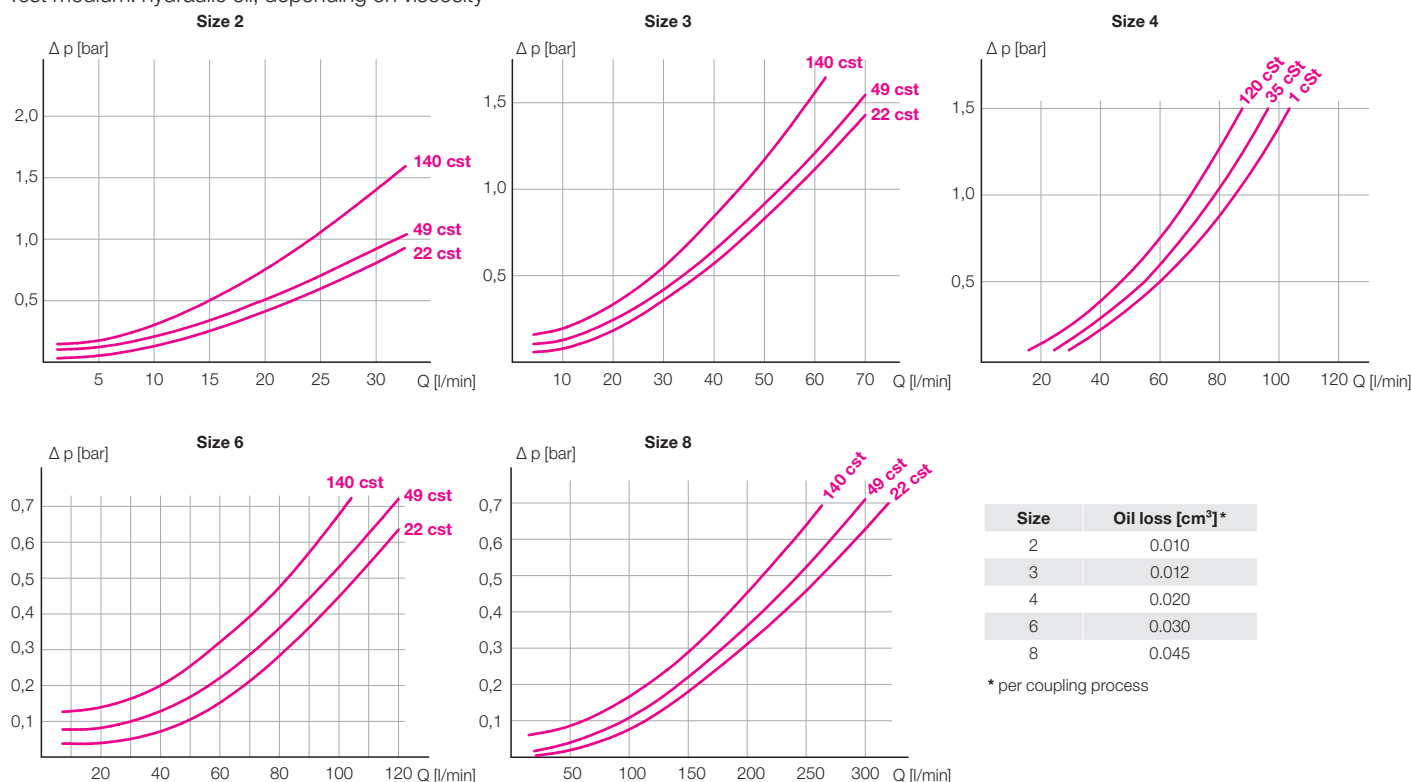

Pipe coupling with pipe connection

Pipe connection as per DIN 2353/ISO 8434-1

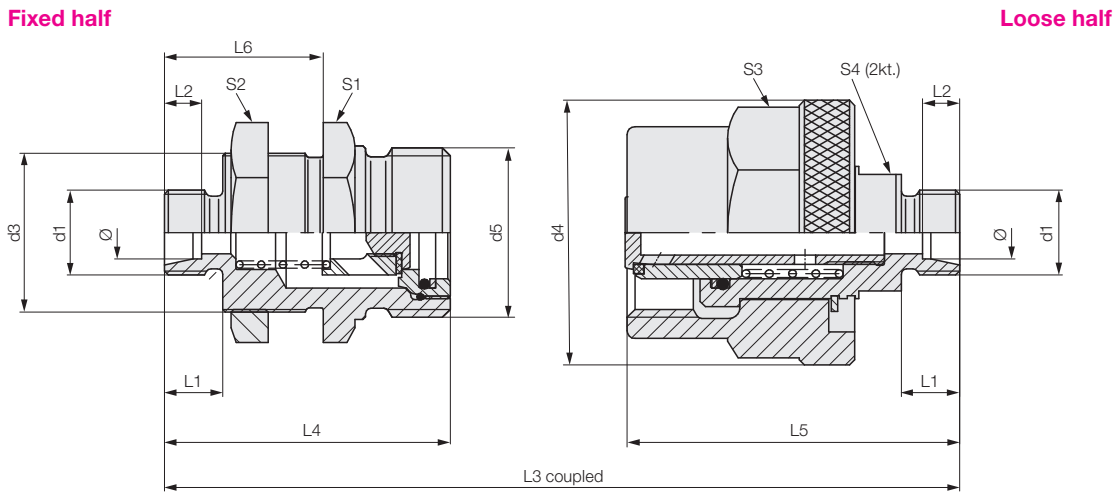

Light series

PB	Size	Pipe Ø	DN	d1	L1	I2	I3	L4	L5	L6	d3	d4	d5	S1	S2	S3	S4	Part no. Fixed half	Part no. Loose half
315	2	8L	6	M14x1.5	10	7	102	54	62	30	M30x1.0	50	spec. Rd32x3	36	36	41	22	9384FL2M01	9384LL2M01
		10L	8	M16x1.5	11	7	103	54	63	30	M30x1.0	50	spec. Rd32x3	36	36	41	22	9384FL2M02	9384LL2M02
		12L	8.4	M18x1.5	11	7	103	54	63	30	M30x1.0	50	spec. Rd32x3	36	36	41	22	9384FL2M03	9384LL2M03
		15L	8.4	M22x1.5	12	7	105	55	64	31	M30x1.0	50	spec. Rd32x4	36	36	41	22	9384FL2M04	9384LL2M04
300	3	15L	11.5	M22x1.5	12	7	115	61	70	35	M36x1.0	55	spec. Rd36x3	41	41	46	24	9384FL3M01	9384LL3M01
300	4	15L	12	M22x1.5	12	7	128	75	81	40	M45x1.5	60	spec. Rd48x3	55	55	50	32	9384FL4M01	9384LL4M01
		18L	14	M26x1.5	12	7.5	128	75	81	40	M45x1.5	60	spec. Rd48x3	55	55	50	32	9384FL4M02	9384LL4M02
300	6	18L	15	M26x1.5	12	7.5	164	90	103	48	M54x1.5	64	spec. Rd54x4	55	60	55	50	9384FL6M01	9384LL6M01
160		22L	19	M30x2.0	14	7.5	168	95	105	50	M54x1.5	64	spec. Rd54x4	55	60	55	50	9384FL6M02	9384LL6M02
		28L	19	M36x2.0	14	7.5	168	92	105	50	M54x1.5	64	spec. Rd54x4	55	60	55	50	9384FL6M03	9384LL6M03
160	8	35L	28	M45x2.0	16	10.5	205	116	129	61	M80x2.0	90	spec. Rd79x4	85			55	9384FL8M01	9384LL8M01
		42L	28	M52x2.0	16	11	205	116	129	61	M80x2.0	90	spec. Rd79x4	85			55	9384FL8M02	9384LL8M02

Heavy series

PB	Size	Pipe Ø	DN	d1	L1	I2	I3	L4	L5	L6	d3	d4	d5	S1	S2	S3	S4	Part no. Fixed half	Part no. Loose half
420	2	10S	7	M18x1.5	12	7.5	106	56	64	32	M30x1.0	50	spec. Rd32x3	36	36	41	22	9384FS2M01	9384LS2M01
		12S	8	M20x1.5	12	7.5	105	56	64	31	M30x1.0	50	spec. Rd32x3	36	36	41	22	9384FS2M02	9384LS2M02
		14S	8.4	M22x1.5	14	8	109	57	66	33	M30x1.0	50	spec. Rd32x3	36	36	41	22	9384FS2M03	9384LS2M03
		16S	8.4	M24x1.5	14	8.5	109	57	66	33	M30x1.0	50	spec. Rd32x4	36	36	41	22	9384FS2M04	9384LS2M04
300	3	16S	11.5	M24x1.5	14	8.5	119	63	72	37	M36x1.0	55	spec. Rd36x3	41	41	46	24	9384FS3M01	9384LS3M01
300	4	16S	12	M24x1.5	14	8.5	132	77	83	42	M45x1.5	60	spec. Rd48x3	55	55	50	32	9384FS4M01	9384LS4M01
		20S	14	M30x2.0	16	10.5	136	79	85	44	M45x1.5	60	spec. Rd48x3	55	55	50	32	9384FS4M02	9384LS4M02
		25S	14	M36x2.0	18	13.5	139	81	86	46	M45x1.5	60	spec. Rd48x3	55	55	50	32	9384FS4M03	9384LS4M03
300	6	20S	16	M30x2.0	16	10.5	172	94	107	52	M54x1.5	64	spec. Rd54x4	55	60	55	50	9384FS6M01	9384LS6M01
		25S	19	M36x2.0	18	12	176	96	109	54	M54x1.5	64	spec. Rd54x4	55	60	55	50	9384FS6M02	9384LS6M02
		30S	19	M42x2.0	20	13.5	180	98	111	56	M54x1.5	64	spec. Rd54x4	55	60	55	50	9384FS6M03	9384LS6M03
420	8	30S	25	M42x2.0	20	13.5	226	123	143	68	M80x2.0	90	spec. Rd79x4	85			55	9384FS8M01	9384LS8M01
		38S	28	M52x2.0	22	16	219	123	136	68	M80x2.0	90	spec. Rd79x4	85			55	9384FS8M02	9384LS8M02

PB = operating pressure [bar] coupled! Uncoupled see nominal pressure chart page 1.

All dimensions in [mm]

Pipe couplings with tapped hole Accessories

Tapped hole as per DIN 3852 T2/ISO 1179-1 (pipe thread)

Fixed half

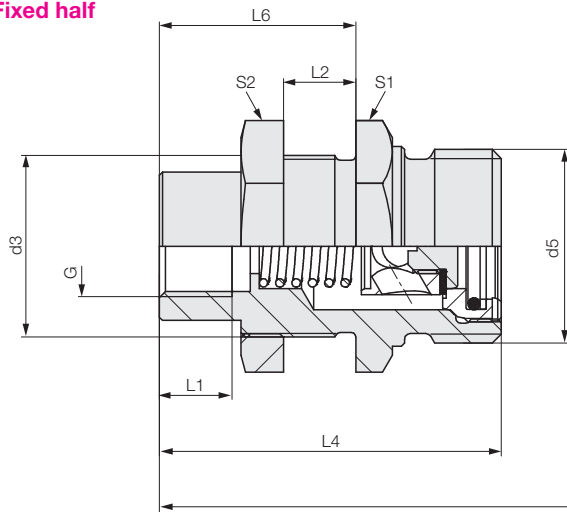

Loose half

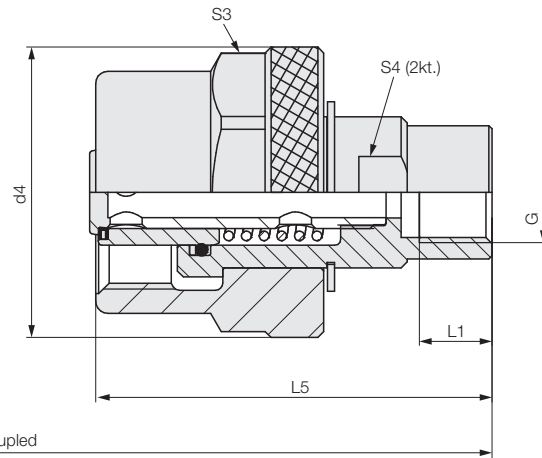

PB	Size	G	DN	L1	I2	I3	L4	L5	L6	d3	d4	d5	S1	S2	S3	S4	Part no Fixed half	Part no. Loose half
420	2	G3/8	8	12	12	109.5	56.5	66	32.5	M30x1.0	50	spec. Rd32x3	36	36	41	22	9384FX2T01	9384LX2T01
300	3	G1/2	11.5	14	16	127	64.5	78.4	38	M36x1.0	55	spec. Rd36x3	41	41	46	24	9384FX3T01	9384LX3T01
300	4	G3/4	14	16	19	143	81	86	46	M45x1.5	60	spec. Rd48x3	55	55	50	32	9384FX4T01	9384LX4T01
300	6	G3/4	16	16	13	174	89	111	46	M54x1.5	64	spec. Rd54x4	55	60	55	50	9384FX6T01	9384LX6T01
		G1	19	18	13	174	93	111	50	M54x1.5	64	spec. Rd54x4	55	60	55	50	9384FX6T02	9384LX6T02
420	8	G1 1/4	25	20	20	220	114	144.5	57	M80x2.0	90	spec. Rd79x4	85			55	9384FX8T01	9384LX8T01
		G1 1/2	28	22	20	241	114	166	57	M80x2.0	90	spec. Rd79x4	85			55	9384FX8T02	9384LX8T02

PB = operating pressure [bar] coupled! Uncoupled see nominal pressure chart page 1.

All dimensions in [mm]

Accessories

Dust protection with flap

(Material dust protection: plastic)

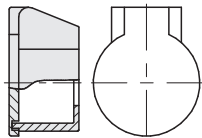

Size	Part no.
2	9384K001

Wall bracket

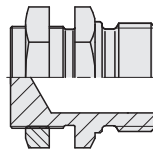

Size	Part no.
2	9384W002
3	9384W003
4	9384W004
6	9384W006

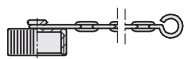

Lock nut

(Material dust protection: aluminium)

Size	Chain length	Part no.
2	170	9384M002
3	170	9384M003
4	230	9384M004
6	230	9384M006
8	230	9384M008



Screw plug

(Material dust protection: aluminium)

Size	Chain length	Part no.
2	170	9384S002
3	170	9384S003
4	230	9384S004
6	230	9384S006
8	230	9384S008