



Spring Clamping Element
10 - 300 N, with and without sealing



These spring clamping elements are designed for quicker, safer and more economic work-piece positioning and clamping within clamping range of 10-300 N.

With sealing

Elements of range 31121XX are equipped with additional sealing against swarf and coolants and are particularly suitable for its application in the metal cutting machining.

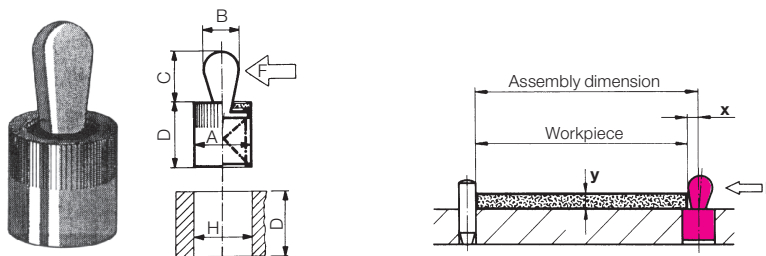

A	B	C	D	H	F	y=1.0	y=2.0	y=3.0	y=4.5	y=6.0	y=8.0	y≥10.0	Weight	Part no.
		-1			[N]	X	X	X	X	X	X	X	[g]	
6	3	4	7	6H11	10	0.8	1.0	1.0	1.0	1.0	1.0	1.0	1	3112120
					20								1	3112121
					40								1	3112122
10	5	6	12	10H11	20		1.5	1.7	1.7	1.7	1.7	1.7	2	3112123
					50								2	3112124
					100								2	3112125
10	6	10	12	10H11	40				1.7	1.9	1.9	1.9	2	3112126
					75								2	3112127
					150								2	3112128
12	8	13	14	12H11	50					2.4	2.6	2.6	8	3112129
					100								8	3112130
					200								8	3112131
16	10	16	18	16H11	100						3.1	3.4	16	3112132
					200								16	3112133
					300								16	3112134

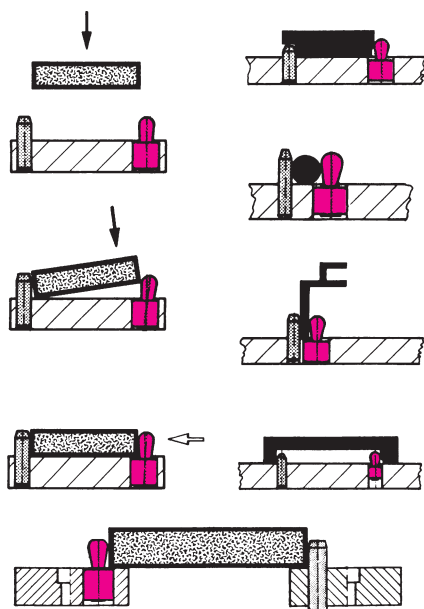

Function

The clamping force is generated by displacement of a spring-loaded pin. Clamping force and clamping path are indicated in the chart.

Materials

Body: aluminium
Pressure pin: steel case hardened and galvanised

Without sealing

Elements of range 31222XX without the extra sealing are suitable for assembly and welding.

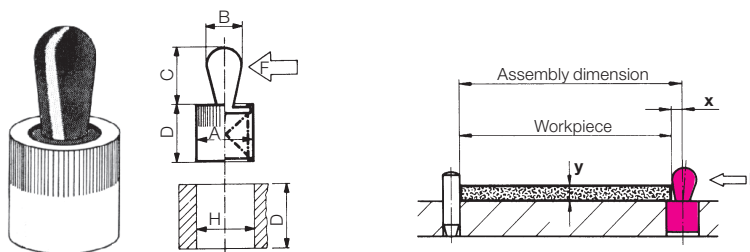

A	B	C	D	H	F	y=1.0	y=2.0	y=3.0	y=4.5	y=6.0	y=8.0	y≥10.0	Weight	Part no.
		-1			[N]	X	X	X	X	X	X	X	[g]	
6	3	5.0	7	6H11	10	0.8	1.0	1.0	1.0	1.0	1.0	1.0	1	3112000
					20								1	3112001
					40								1	3112002
10	5	7.7	11	10H11	20		1.5	1.7	1.7	1.7	1.7	1.7	2	3112003
					50								2	3112004
					100								2	3112005
10	6	11.6	11	10H11	40				1.7	1.9	1.9	1.9	2	3112006
					75								2	3112007
					150								2	3112008
12	8	15.1	13	12H11	50					2.4	2.6	2.6	8	3112009
					100								8	3112010
					200								8	3112011
16	10	18.2	17	16H11	100						3.1	3.4	16	3112012
					200								16	3112013
					300								16	3112014

Mounting

Tools as per chart opposite are available for mounting. Insertion into bore hole can be effected by hammer or press (see fig.).

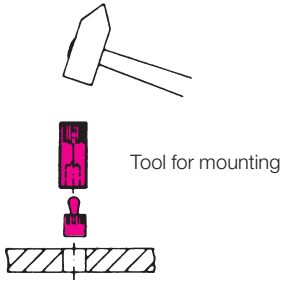

Tools for mounting

5 sizes as per dimension B as per chart page 1.

	Part no.
3	3112 140
5	3112 141
6	3112 142
8	3112 143
10	3112 144

Application examples

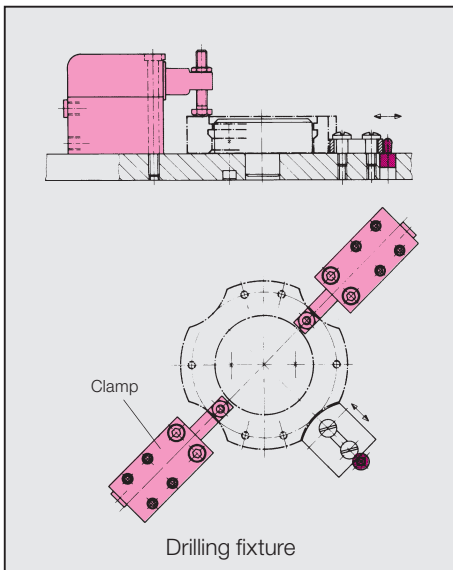

Drilling fixture

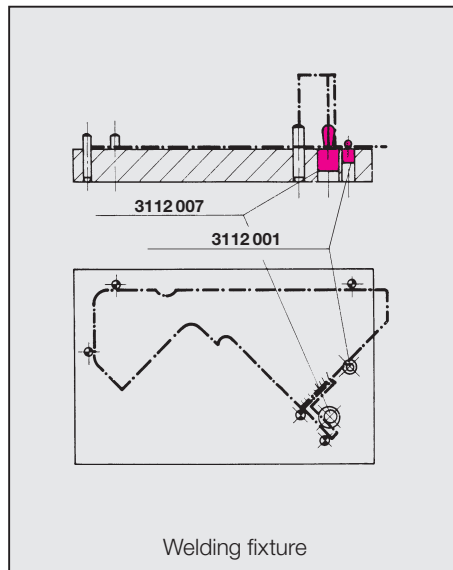

Welding fixture

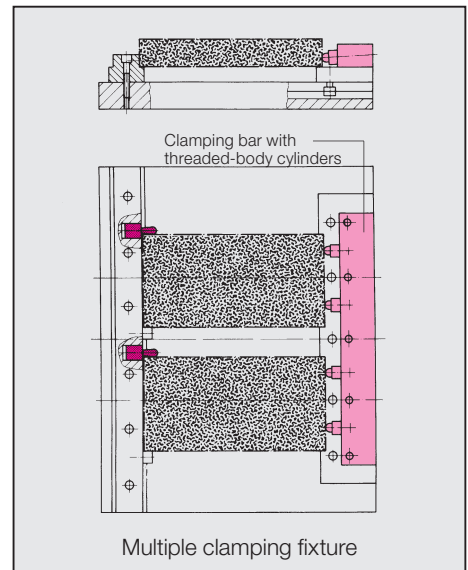

Multiple clamping fixture

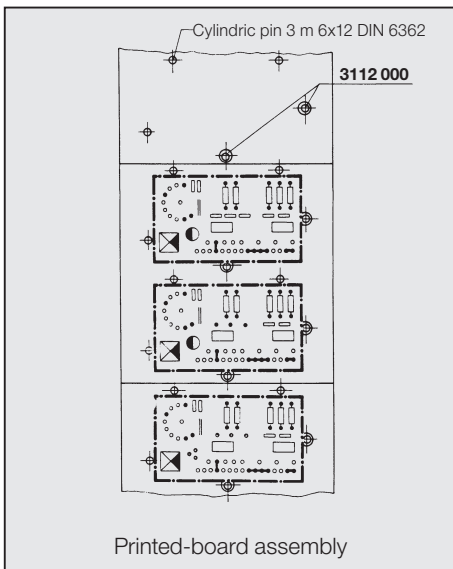

Printed-board assembly

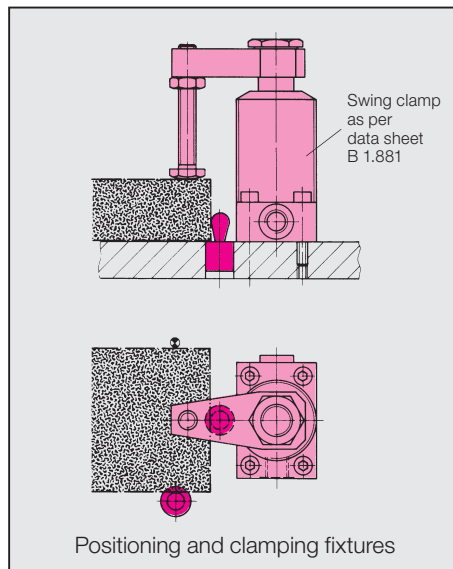

Positioning and clamping fixtures

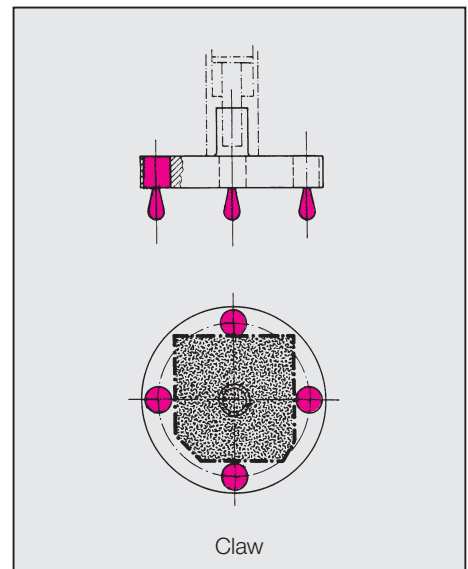

Claw