

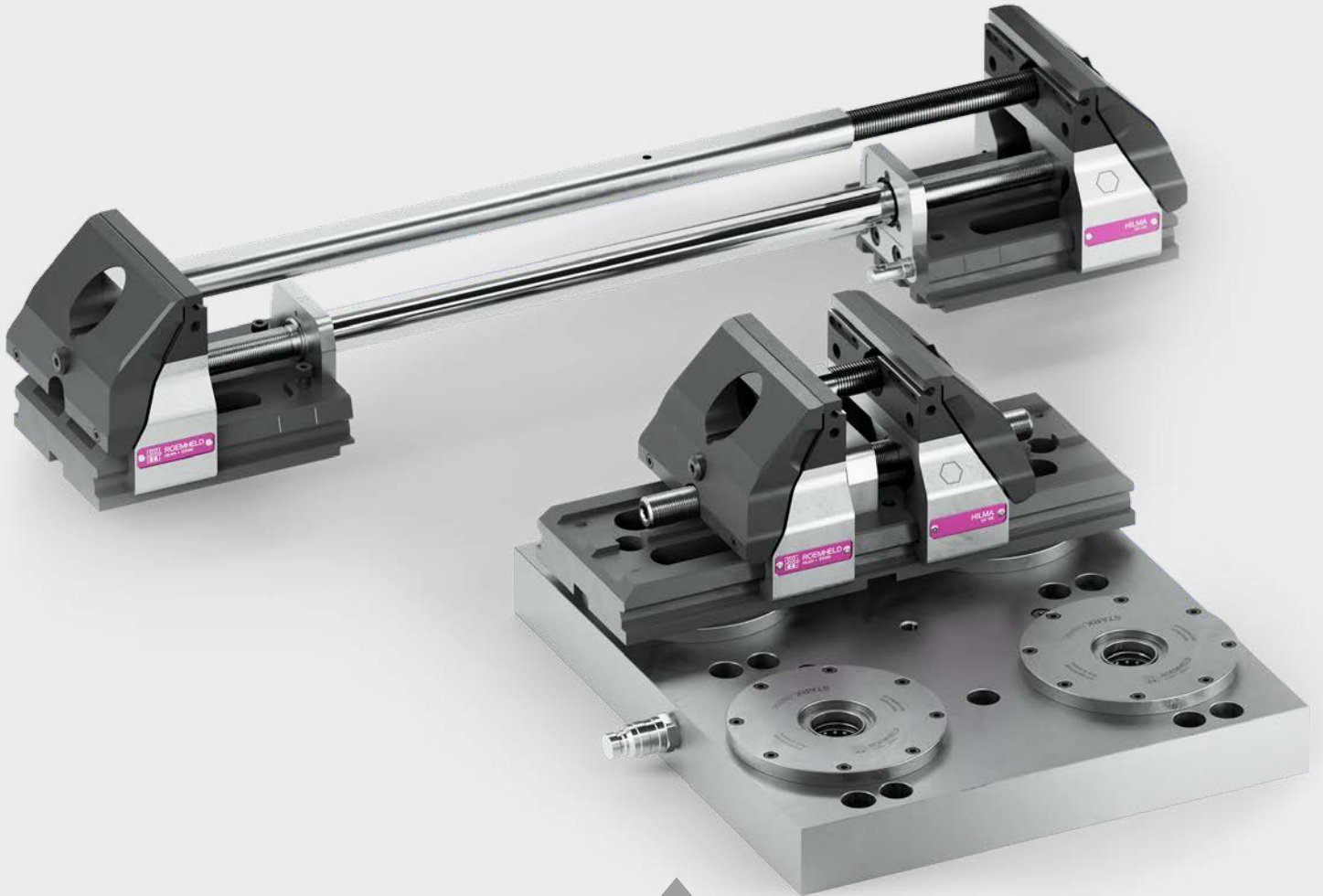

**ROEMHELD**  
HILMA ■ STARK



# HILMA.UC

## 5-axis clamping system

Concentric, modular, precise

Jaw width 125 mm



**ROEMHELD**  
HILMA ■ STARK



# STARK INNOVATIVE PROFICIENT INDIVIDUAL SAFE

The high-tech company STARK Spannsysteme was established in 1977 in Rankweil, Austria. It manufactures zero point clamping systems and vises of the highest quality and precision for international clients in the automotive, aviation and medical industries, for example.

STARK Spannsysteme products are a byword for minimal set-up times, faster production and high flexibility.

HILMA vises can be complemented and combined perfectly with STARK zero point clamping systems.

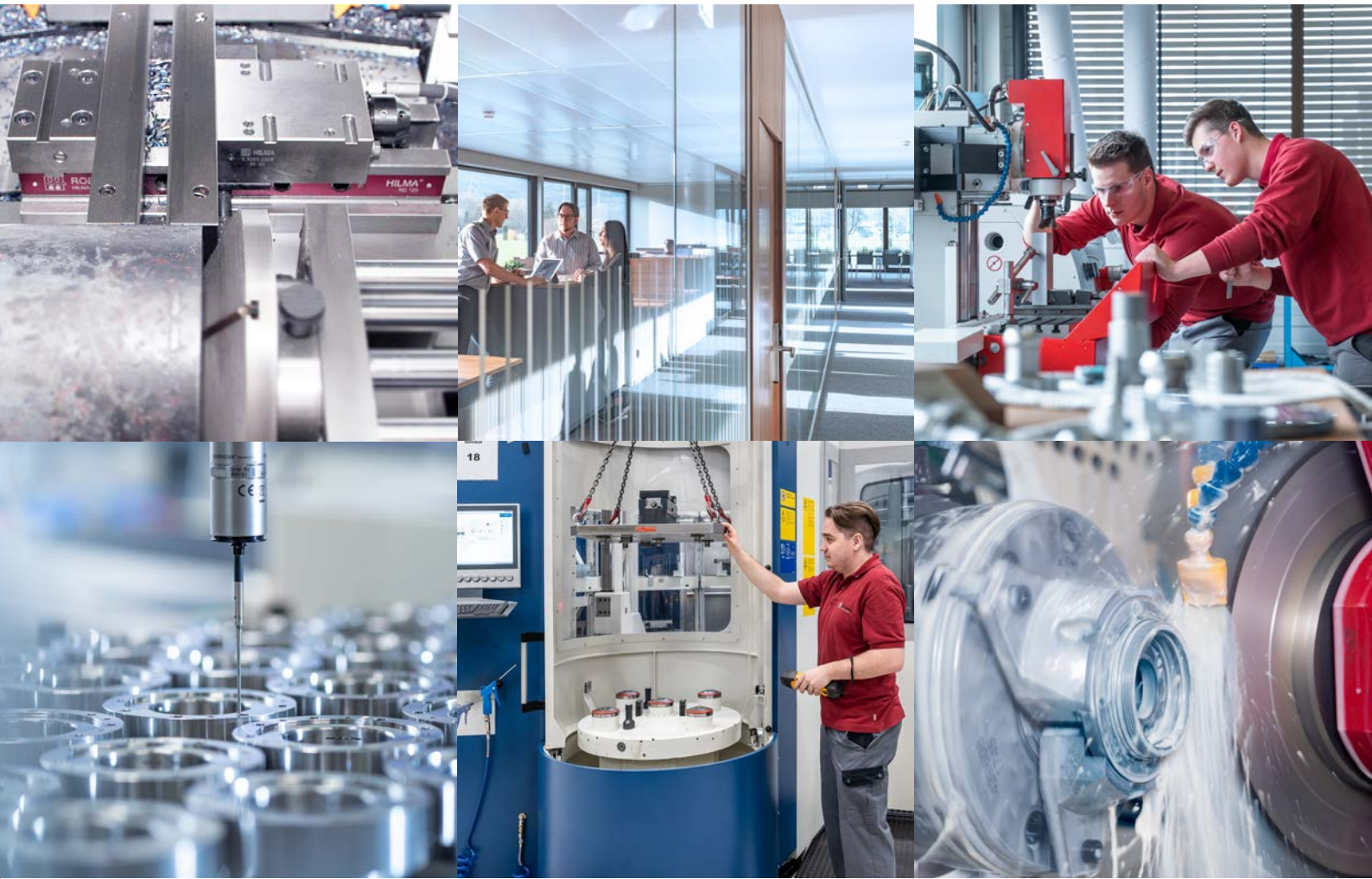

AUTOMOTIVE



AVIATION



MACHINE AND TOOL  
CONSTRUCTION



MEDICINE

# FOCUS ON INDUSTRIES & MARKETS.

Every customer has specific requirements. Our established and extensive industry expertise allows us to offer you the best solutions, services and products for sustainable and efficient use in your market.

# HILMA.UC 125

**UNIVERSAL**  
**STABLE**  
**COMPACT**  
**PRECISE**

Modular system allows for versatile clamping possibilities  
No deflection and complete locking thanks to new physics  
Reduced design ensures optimum accessibility  
True to position due to pull-down mechanism

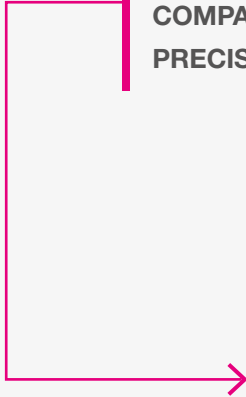

HILMA.UC



HILMA.MCP



HILMA.SCS



HILMA.KNC



HILMA.NC



HILMA.DS



HILMA.ASE



HILMA.ASH



HILMA.SCT



HILMA.TS Vector



HILMA.TS TriStar

5-AXIS MACHINING

VERTICAL MACHINING

HORIZONTAL MACHINING

AUTOMATION

## HILMA Workpiece clamping systems

More productivity through:

- maximum flexibility in production
- highest process reliability
- reduced manufacturing costs through set-up time optimisation

# HILMA.UC TABLE OF CONTENTS

<b>HILMA.UC 5-axis clamping system</b>	<b>6</b>	<b>Fastening versions</b>	<b>26</b>
Advantages	8	Retractable nipple for zero point clamping system	28
Functioning	10	Fast closing plates for zero point clamping system	29
		Adapter plates	30
		Raiser	31
		Fastening set	32
<b>HILMA.UC 125 Machine vise</b>	<b>11</b>		
		<b>Accessory</b>	
		Hexagonal ball head insert	
		Inserts for threads	
		Support clamping nut	
		Precision workpiece stop	33
		<b>List of order numbers</b>	<b>34</b>
<b>Flexible clamping widths</b>	<b>12</b>		
Extension sets	14		
Extension sets with lower part extension	16		
<b>Extensive range of clamping jaws</b>	<b>18</b>		
Pull-down clamping jaws			
Clamping jaws 60 mm, smooth			
Clamping jaws 125 mm, smooth			
Clamping jaws 60 mm, GripPins	20		
Clamping jaws 125 mm, GripPins			
Pendulum jaw, GripPins			
GripPins	21		
Prism jaws			
Support rail set	22		
Clamping jaws, soft			
Clamping jaws with round clamping bolt			
Round clamping bolt	23		
<b>Central jaw system</b>			
Base	24		
Central jaw 125 mm, smooth			
Central jaw 125 mm, GripPins			
Heavy-duty support	25		

# HILMA.UC

## 5-axis clamping system

Patented pull-down mechanism  
for the highest precision

Extensive range of clamping jaws for different  
clamping tasks

Support rails for different clamping depths

The centre bearing holds the workpiece precisely in the  
centre with repetitive accuracy

Wide guides of the clamping slides  
Clamped without air gap and without mechanical load

Slot nuts for positioning

Retractable nipple for  
STARK zero point clamping system

— Basic machine vise

— Options & accessories

Central jaw system for multi-part clamping or as heavy-duty support



Tension spindles and clamping nuts for jaw openings 0 - 200 mm included in the standard scope of delivery

Accessories for extended jaw openings up to 1000 mm with / without lower part extension



The mechanical actuation takes place via the self-cleaning tension spindle with fine thread

Workpiece stop

Symbol for operating side

Cover plate for protection against swarf and stroke limitation



The self-cleaning adjustment spindle is not mechanically loaded - it is only used for positioning

Raiser for optimised accessibility

Adapter plates for more flexibility

Holes for zero-point clamping system  $\varnothing 25 / 5$  mm as standard version in the lower part, in raisers and in adapter plates

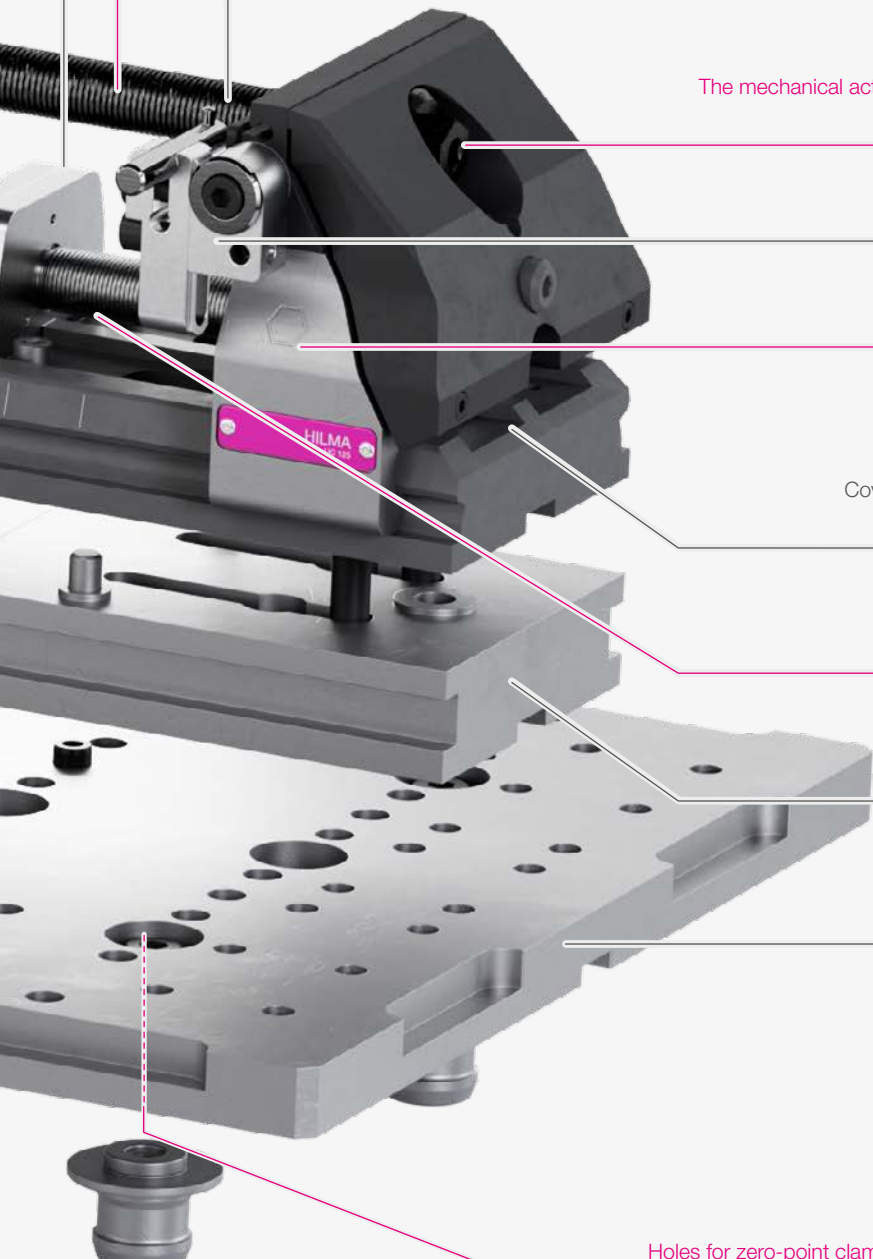

MAXIMUM FLEXIBILITY

THE **HILMA.UC** machine vise

The clamping system **HILMA.UC** is suitable for numerous clamping tasks and is used for machining dimensionally stable workpieces in single or multiple clamping systems. Even if production requirements change, no further investment in new clamping devices is required.

- + Adaptation to different workpiece sizes and geometries in a few simple steps - Low interference contour
- + High stability - low load on tools - less tool wear

- For series and individual production
- For 3-, 4- or 5-axis machining centres
- Milling machines and milling/turning centres
- Mechanical spindle applies a pulling force of up to 52kN (120Nm)
- Centric clamping

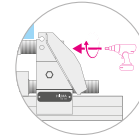

**Operation**  
Mechanical

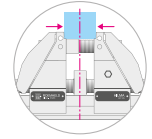

**Clamping principle**  
concentric

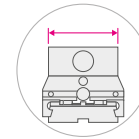

**Jaw width**  
125mm

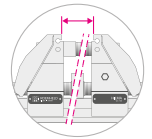

**Clamping width**  
0 - 1000mm



**High stability - outstanding clamping quality**

- Separation of adjusting and tension spindles for a closed and even force flow - no bending force effect on the lower part
- + in clamped state - no air gap - no vibrations - no deflection
- + Less tool wear
- Reduction of the necessary clamping force and simultaneously high clamping quality
- + Less workpiece deformation for maximum dimensional accuracy
- + Ideal for delicate workpieces
- Pull-down clamping jaws
- + Secure hold due to active pull-down clamping of the workpiece

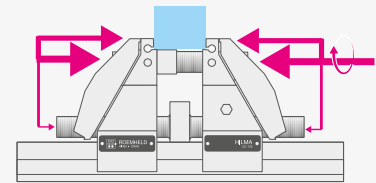

**Optimum accessibility**

- Compact design
- + Good accessibility - optimum tool length can be used due to minimum interference contour
- Raiser as accessory
- + Improved accessibility for special clamping tasks
- ▶ More about raisers on page 31

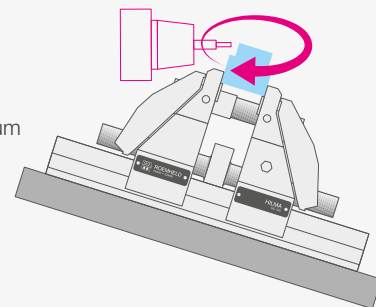



### Concentric clamping system

- Centre clamp, optimal for 5-axis applications
- + Precise and repeatable
- + Split mounting option

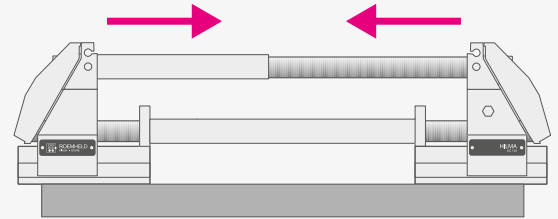

### Flexible clamping width & range of clamping jaws

- Standard jaw opening from 0 - 200mm, extension sets for extended jaw opening up to 1000mm
- Conclusive range of clamping jaws for workpieces in all shapes and surfaces from round to square, small to large and smooth or uneven
- + Can be adapted to workpiece geometries of different sizes in just a few simple steps
- + Variable clamping depths
- + Optimised accessibility
  - ▶ More about the extension sets on page 12
  - ▶ More about the range of clamping jaws on page 18

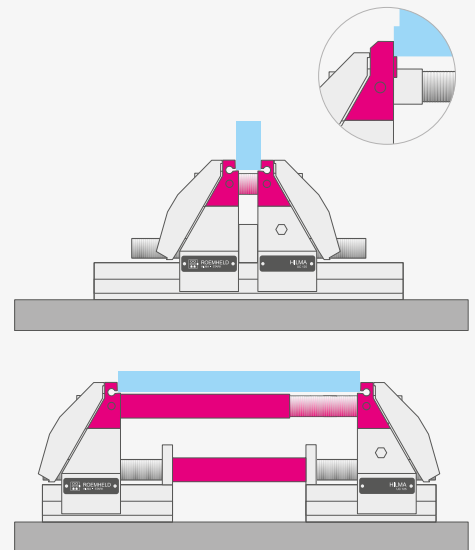

### Individual fixation

- Fixation with keyblock on T-slot table
- Fixation with clamping claws
- Fixation from above through the base by means of screws
- Quick change by means of STARK draw-in nipple directly or via adapter plate in the STARK zero point clamping system
- Thread adapter for alternative zero point clamping system manufacturers
- Standard fast-clamping plates available
- ▶ More about fixation on page 26

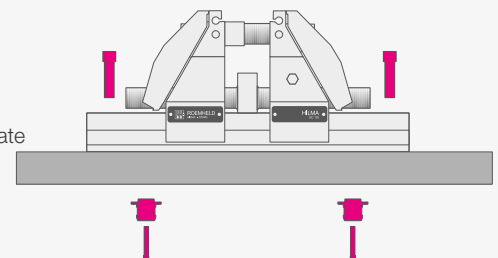

CONCENTRIC CLAMPING DEVICE WITH PULL-DOWN MECHANISM

Operating principle **HILMA.UC**

**INFO**

Clamping principle - Closed force flow

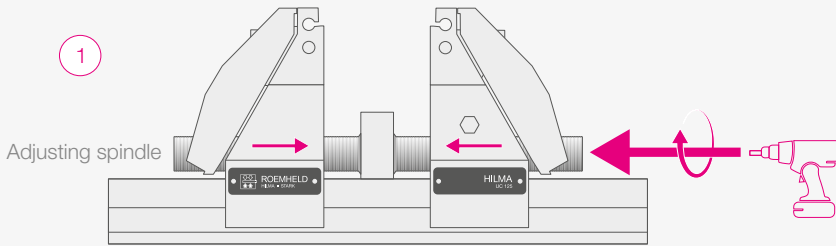

- ① The clamping range is preset until both clamping jaws are in contact with the workpiece without building up clamping force.

Turning the adjustment spindle clockwise moves both adjustment elements to the centre.

Pull-down effect

- ②

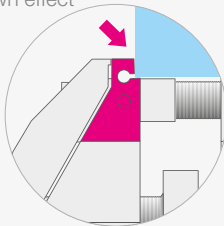

Other clamping principles

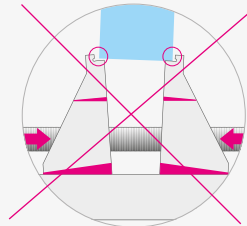

- ② The tension spindle is mounted hand-tight before the clamping force is applied by turning it clockwise using a torque wrench.

The force on the clamping jaws above the workpiece stop is introduced into the workpiece via the outer edges of the clamping claws.

The clamping force develops proportionally to the torque.

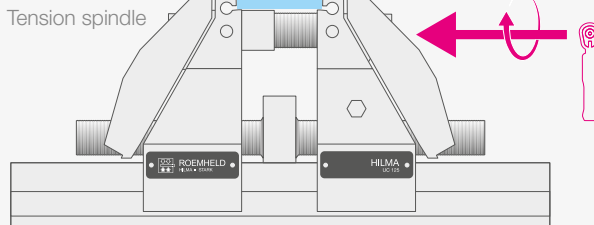

- ③ Most of the pulling force is applied directly to the workpiece. The adjustment spindles serve as counter bearings.

The adjustment elements are clamped to the base plate and the system is completely mechanically locked.

Due to the closed force flow from tension spindle to adjustment spindle, the base remains almost without bending force being applied and tilting of the adjustment elements is avoided.

- ③

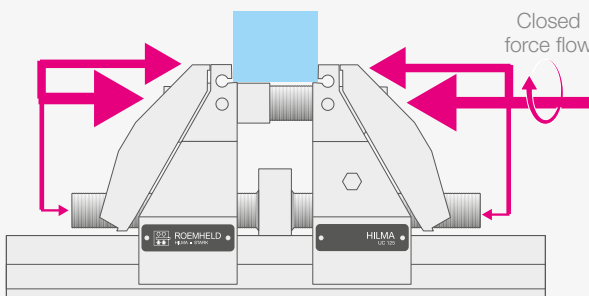

## HILMA.UC 125

The **HILMA.UC 125** is a universal 5-axis concentric clamp with mechanical actuation and a jaw width of 125 mm. The clamping nuts

and tension spindles included in the standard scope of supply allow a maximum clamping range of 200 mm, which can be extended to 1000 mm with extension sets. The concentric clamp is supplied with pull-down clamping jaws for clamping pre-machined and smooth surfaces. Draw-in nipple bore holes for zero point clamping systems are prepared in the base for fixation.



Figure: 970230101  
Standard scope of delivery:  
Machine vise incl. pull-down clamping jaws, clamping nut, short and long, tension spindle, short and long

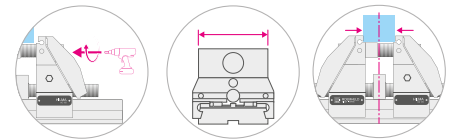

Operation Mechanical

Jaw width 125 mm

Clamping principle concentric

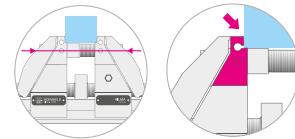

Pull force 52 kN

Pull-down mechanism

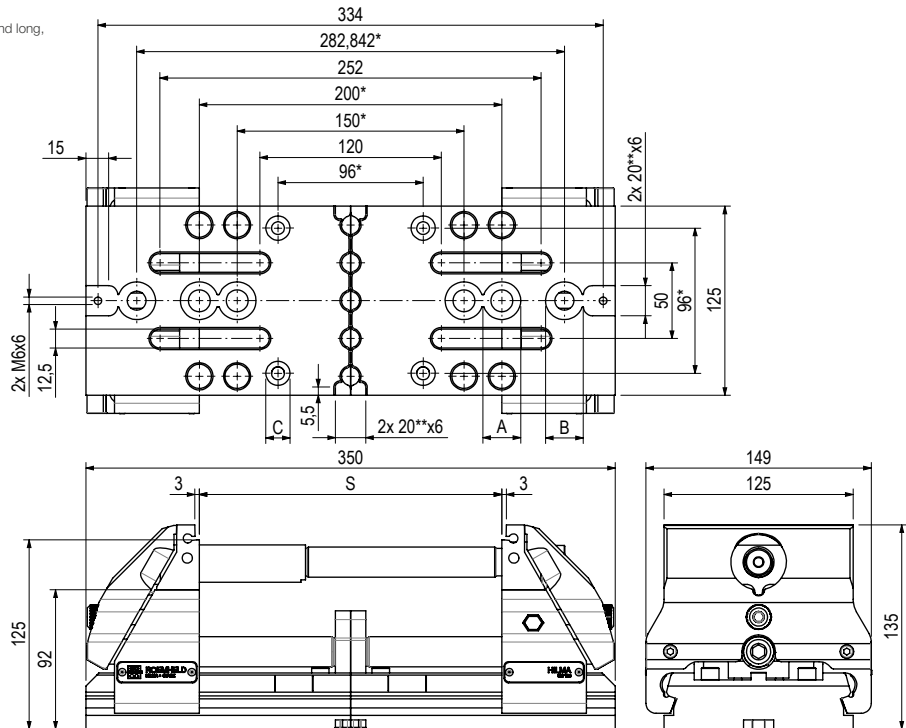

Z\_970230101\_05

\* Tolerance ± 0.02, \*\* tolerance + 0.02  
All dimensions in [mm]

Series		HILMA.UC 125
Operation		Mechanical
Lower part length <sup>1)</sup>	[mm]	350
Pull force	[kN]	52
Clamping principle		concentric
Clamping range S <sup>2)</sup>	[mm]	0 - 200 (max. 1000)
Retractable nipple bore A	[mm]	4 × Ø 25 H7 × 6; 4 × M16 × 1.5 × 18
Retractable nipple bore spacing	[mm]	96 / 150 / 200 / 282.842
Bore hole for fixation from above B	[pcs.]	2 × Ø 25 H7 × 6; 2 × flat sink for M12 from above
96 × 96 retractable nipple spacing C	[mm]	4 × Ø 16 ± 0.01 × 6; 4 × M10 × 10
Weight with pull-down clamping jaws	[kg]	20
Order no.		970230101

<sup>1)</sup> Base part length without extension with a clamping range of max. 200 mm  
<sup>2)</sup> Extension sets for clamping ranges up to 1000 mm available as accessories ► More on page 13  
Subject to technical changes, all information without guarantee

EXTENSION SETS FOR MAXIMUM CLAMPING WIDTHS

# Flexible clamping widths

The concentric clamping system can be divided in the middle and extended. The clamping range can be extended up to 1000 mm by using different tension spindle/clamping nut combinations.

A closed force flow is created between the tension spindle, adjustment element and clamping jaw, thus allowing the modular design. The base plate remains without bending force application.

The extended clamping system can be mounted directly on the machine table, the raisers or on adapter plates with or without a lower part extension.

## Standard jaw opening 0 - 200mm

Four elements for adjusting the clamping range are included in the standard scope of supply.

- Tension spindle, short
- Tension spindle, long
- Clamping device, short
- Clamping nut, long



The following clamping ranges can be combined

**0 - 50 mm**

Short tension spindle and short clamping nut



**48 - 104 mm**

Short tension spindle and short clamping nut



**100 - 200 mm**

Long tension spindle and long clamping nut

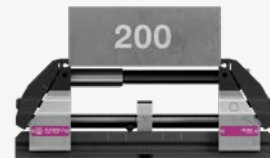

Example:  
Extension set



+ **MAXIMUM FLEXIBILITY**

Clamping range can be extended modularly up to 1000 mm by means of tension spindles and clamping nuts.

+ **COST-EFFICIENT LIGHTWEIGHT CONSTRUCTION**

Reduced use of materials increases cost efficiency and makes handling easier at the same time.

+ **VERSATILE ASSEMBLY**

Direct attachment to machine table, raisers or adapter plates possible

Example:  
Extension set with lower part extension



+ **MAXIMUM STABILITY**

The fixed connection of the clamping halves forms a compact unit, ideal for large clamping ranges up to 1000 mm.

+ **PROCESS RELIABILITY AND OPTIMISED SET-UP TIMES**

The lower part extension enables fast, precise and repeatable positioning, which is particularly advantageous for frequent retrofitting.

+ **EXTENDED APPLICATION POSSIBILITIES**

The variable use of the centre jaw allows optimum adaptation to changing clamping tasks.

**INFO**

Application examples

Assembly on an adaptor plate

Using the extension sets in combination with an adapter plate allows very quick and easy retrofitting.



Example:

- Extension set 200 - 400 mm long tension spindle
- Clamping nut 300 mm
- Adjustable spindle extension 200 mm
- Adapter plate 150x400 mm

Mounting on a STARK zero point clamping system.

The lower part extension enables the HILMA.UC to be changed quickly without any alignment work. The tensioner remains a compact unit both when installed and removed.



Example:

- Lower part extension set 200 - 400 mm long tension spindle
- Clamping nut 300 mm
- Lower part extension 200 mm
- STARK.classic.2 retractable nipple incl. fixing screws
- Fast closing plate

Mounting on a machine table transverse to the centre reference groove

The lower part extension enables the vise to be aligned with the centre reference groove of the machine table.



Example:

- Lower part extension set 200 - 300 mm
- Tension spindle, long
- Clamping nut 300 mm
- Lower part extension 100 mm
- Fastening set
- 2 x slot nuts 14/18 incl. fixing screws
- 4 x keyblocks incl. fixing screws

## Extension sets

### Maximum flexibility for every clamping task

The modular extension sets enable flexible expansion of the clamping range for a wide range of workpiece sizes.

With an extension set, all clamping ranges from 200 mm up to the maximum set length can be flexibly covered - all the necessary components are included.

Thanks to the modular design, clamping widths of up to 1000 mm can be realised without the need for a fixed lower part extension.

Thanks to direct mounting on machine tables, raisers or adapter plates, the clamping technology remains versatile. The reduced design ensures a lower weight and easy handling, while the closed force flow between the ten-

sion spindle, adjustment element and clamping jaw ensures high stability.

The extension sets are the ideal choice for users who require maximum flexibility without compromising on precision and stability.

### Extension set up to 300 mm



Order no.	Description	Scope of delivery
970235038	Extension set 200-300mm	1 pc. adjustable spindle extension 100mm 1 pc. clamping nut 300mm

### Extension set up to 400 mm



Order no.	Description	Scope of delivery
970235056	Extension set 200-400mm	1 pc. adjustable spindle extension 200mm 1 pc. modulat clamping nut 400mm 1 pc. socket wrench 12mm 1/2"

### Extension set up to 600 mm



Order no.	Description	Scope of delivery
970235057	Extension set 200-600mm	1 pc. adjustable spindle extension 200mm 1 pc. adjustable spindle extension 400mm 1 pc. modulat clamping nut 600mm 1 pc. socket wrench 12mm 1/2"

### Extension set up to 800 mm





Order no.	Description	Scope of delivery
970235046	Extension set 200-800mm	1 pc. adjustable spindle extension 200mm 1 pc. adjustable spindle extension 400mm 1 pc. modulat clamping nut 800mm 1 pc. socket wrench 12mm 1/2"

### Extension set up to 1000 mm



Order no.	Description	Scope of delivery
970235047	Extension set 200-1000mm	1 pc. adjustable spindle extension 200mm 2 pc. adjustable spindle extension 400mm 1 pc. modulat clamping nut 1000mm 1 pc. socket wrench 12mm 1/2"

## Clamping range

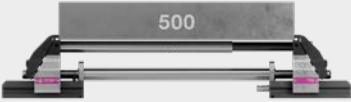
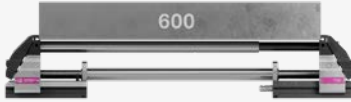
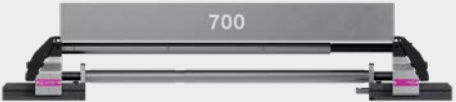
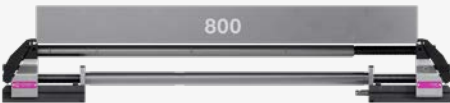
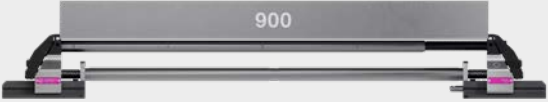
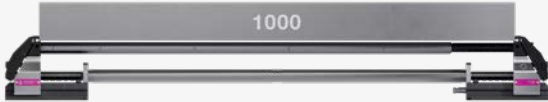
Clamping range	Extension set	
200 - 300mm	Adjustable spindle extension 100 mm or 200 mm Clamping nut 300 mm	
300 - 400mm	Adjustable spindle extension 200 mm Clamping nut 400 mm	
400 - 500mm	Adjustable spindle extension 400 mm Clamping nut 500 mm	
500 - 600mm	Adjustable spindle extension 400 mm Clamping nut 600 mm	
600 - 700mm	Adjustable spindle extension 400 mm + 200 mm Clamping nut 700 mm	
700 - 800mm	Adjustable spindle extension 400 mm + 200 mm Clamping nut 800 mm	
800 - 900mm	Adjustable spindle extension 400 mm + 400 mm Clamping nut 900 mm	
900 - 1000mm	Adjustable spindle extension 400 mm + 400 mm Clamping nut 1000mm	

### INFO

### Modular clamping nut

The modular clamping nut can be flexibly retrofitted for different clamping ranges using a socket wrench - for example from 600 mm to 500 mm by removing the 100 mm extension. All clamping ranges from 200 mm to the specified maximum value can be individually configured from the components included in the set.



## Extension sets with lower part extension

### Stability and easy handling for larger clamping widths

The extension sets with lower part extension offer a particularly stable and user-friendly solution for larger clamping ranges of up to 1000 mm.

With an extension set, all clamping ranges from 200 mm up to the maximum set length can be flexibly covered - all the necessary components are included.

The firm connection of the two clamping halves creates a compact unit that remains stable even when not clamped.

The integrated lower part extension makes it easier to align the clamping halves and ensures fast, repeatable positioning - ideal for frequent changeovers. It also enables flexible use of the central jaw, allowing the clamping system to be

optimally adapted to changing requirements. This reduces the set-up effort and increases process reliability at the same time.

This variant is the perfect choice for users who value maximum stability, easy handling and time-saving set-up.

### Lower part extension set up to 300 mm



Order no.	Description	Scope of delivery
970235048	Lower part extension set 200-300 mm	1 pc. lower part and adjustable spindle extension 100 mm 1 pc. clamping nut 300 mm

### Lower part extension set up to 400 mm



Order no.	Description	Scope of delivery
970235049	Lower part extension set 200-400 mm	1 pc. lower part and adjustable spindle extension 200 mm 1 pc. modulat clamping nut 400 mm 1 pc. socket wrench 12 mm 1/2"

### Lower part extension set up to 600 mm



Order no.	Description	Scope of delivery
970235050	Lower part extension set 200-600 mm	1 pc. lower part and adjustable spindle extension 200 mm 1 pc. lower part and adjustable spindle extension 400 mm 1 pc. modulat clamping nut 600 mm 1 pc. socket wrench 12 mm 1/2"

### Lower part extension set up to 800 mm



Order no.	Description	Scope of delivery
970235051	Lower part extension set 200-800 mm	1 pc. lower part and adjustable spindle extension 200 mm 1 pc. lower part and adjustable spindle extension 400 mm 1 pc. modulat clamping nut 800 mm 1 pc. socket wrench 12 mm 1/2"

### Lower part extension set up to 1000 mm



Order no.	Description	Scope of delivery
970235052	Lower part extension set 200-1000 mm	1 pc. lower part and adjustable spindle extension 200 mm 2 pcs. lower part and adjustable spindle extension 400 mm 1 socket wrench 12 mm 1/2" 1 pc. modulat clamping nut 1000 mm

## Clamping range

Clamping range	Extension set	
200 - 300mm	Lower part and adjustable spindle extension 100 mm or 200 mm Clamping nut 300mm	
300 - 400mm	Lower part and adjustable spindle extension 200mm Clamping nut 400mm	
400 - 500mm	Lower part and adjustable spindle extension 400mm Clamping nut 500mm	
500 - 600mm	Lower part and adjustable spindle extension 400mm Clamping nut 600mm	
600 - 700mm	Lower part and adjustable spindle extension 400mm + 200 mm Clamping nut 700mm	
700 - 800mm	Lower part and adjustable spindle extension 400mm + 200 mm Clamping nut 800mm	
800 - 900mm	Lower part and adjustable spindle extension 400mm + 400mm Clamping nut 900mm	
900 - 1000mm	Lower part and adjustable spindle extension 400mm + 400 mm clamping nut 1000mm	

► Note: more on the modular clamping nut on page 15

### INFO

#### Support clamping nut

To optimise the handling of the long clamping nut, supports can be mounted on all connection points of the lower parts.

► More about supports on page 33



THE OPTIMUM JAW FOR EVERY WORKPIECE  
**Extensive range of jaws**

High clamping quality



High clamping safety

The jaws used have a major influence on the machining result. The range of clamping jaws enables reliable blank and finished part clamping in all shapes from round to square and from small to large and from small to large.

For smooth clamping jaws, clamping jaws with GripPins and for the pendulum jaw, support rails are required as workpiece support.

► More about support rails on page 22



**Finished parts**

Clamping jaw 125 mm & 60 mm, smooth  
Page 20



**Blanks**

Clamping jaw with GripPins 125 mm & 60 mm  
Page 20 & 21



**Workpiece stop**

Swivelling positioning aid  
Page 33



**Three-point clamping**

Clamping jaw with round clamping bolt  
Page 23



**Blank with angular error**

Pendulum jaw  
Page 21

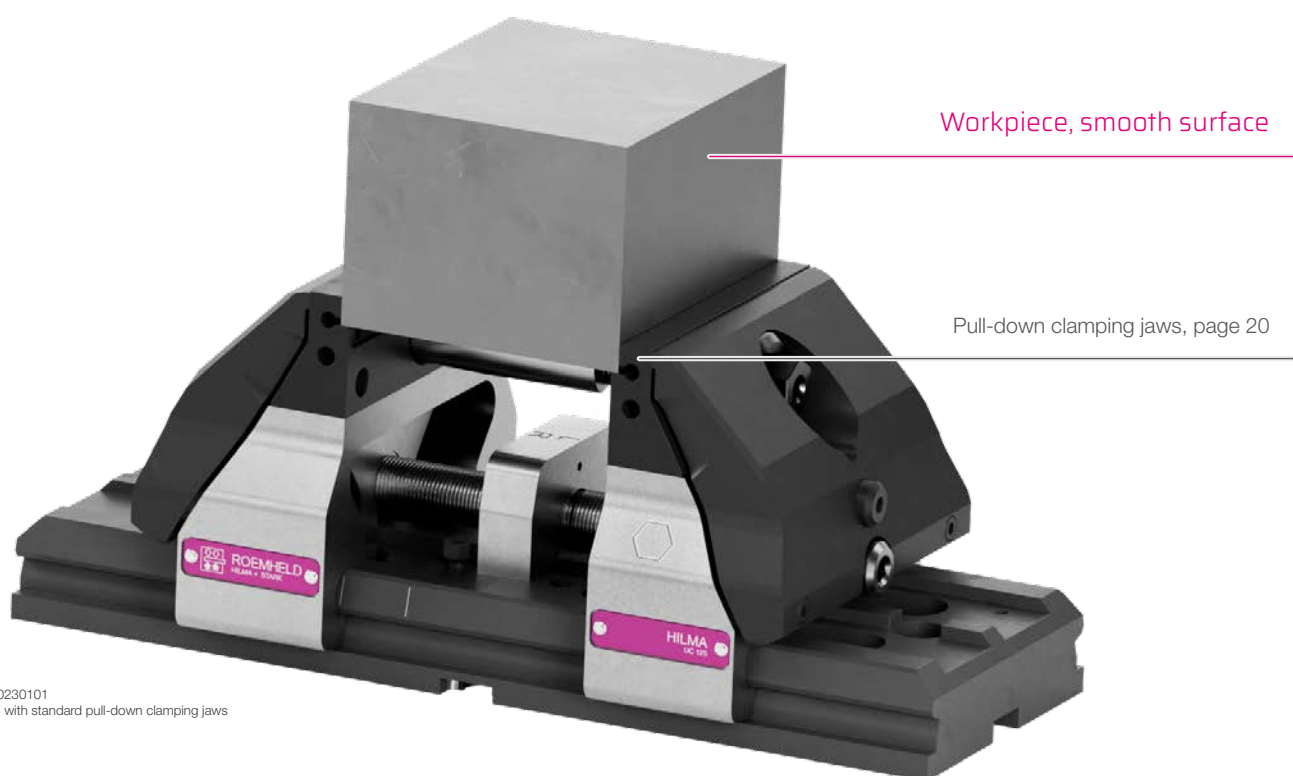

Figure: 970230101  
HILMA.UC with standard pull-down clamping jaws



**Round parts, large**

Clamping jaw with round clamping bolt  
Page 23



**Cylindrical workpiece**

Vee jaw  
Page 22



**Workpiece with special shape**

Clamping jaw, soft with specific clamping contour  
Page 23

### Pull-down clamping jaws 125 mm, hardened

Suitable for clamping pre-machined or smooth surfaces (second side). The bending element of the jaw clamps the workpiece with pull-down and presses it onto the support surface with repetitive accuracy.

Support rails are optional for the clamping jaw. ▶ Page 22

Pull-down clamping jaws are included in the HILMA.UC standard scope of supply.

Order no.	Clamping range	Scope of delivery
970236001	6 - 206 mm*	2 pcs. clamping jaws 4 pcs. fixing screws

\* Standard clamping range without extension set

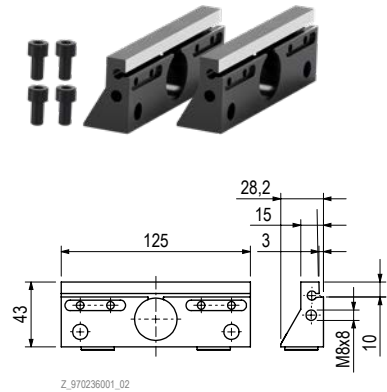

All dimensions in [mm]  
Fastening material included in scope of delivery

### Clamping jaws 60 mm, smooth, hardened

For clamping pre-machined or smooth surfaces (second side). The narrow version of the clamping jaw has a clamping width of 60 mm and serves to optimise accessibility for narrow workpieces.

The maximum clamping depth is 28 mm. Support rails are required for the clamping jaw. ▶ Page 22

Order no.	Clamping range	Scope of delivery
970236007	0 - 190 mm*	2 pcs. clamping jaws 4 pcs. fixing screws

\* Standard clamping range without extension set

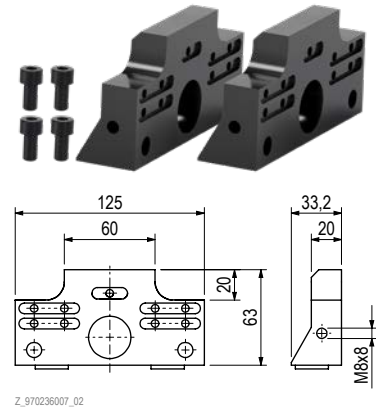

All dimensions in [mm]  
Fastening material included in scope of delivery

### Clamping jaws 125 mm, smooth, hardened

For clamping pre-machined or smooth surfaces (second side). The clamping jaw has a clamping width of 125 mm, the maximum clamping depth is 28 mm. Support rails are required for the clamping jaw. ▶ Page 22

Order no.	Clamping range	Scope of delivery
970236006	0 - 190 mm*	2 pcs. clamping jaws 4 pcs. fixing screws

\* Standard clamping range without extension set

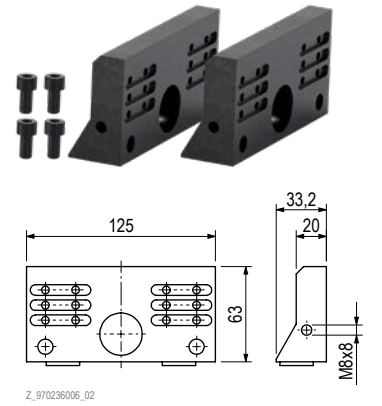

All dimensions in [mm]  
Fastening material included in scope of delivery

### Clamping jaws 60 mm, GripPins

For secure clamping of uneven surfaces such as saw cuts, blanks and cast parts. The narrow version of the clamping jaw with GripPins has a clamping width of 60 mm and serves to optimise accessibility for narrow workpieces.

Caution: Marks of the pins on the workpiece. The maximum clamping depth is 28 mm. Support rails are required for the clamping jaw. ▶ Page 22

Order no.	Clamping range	Scope of delivery
970236003	0 - 190 mm*	2 pcs. clamping jaws incl. 2 x 6 pcs. GripPins 4 pcs. fixing screws

\* Standard clamping range without extension set

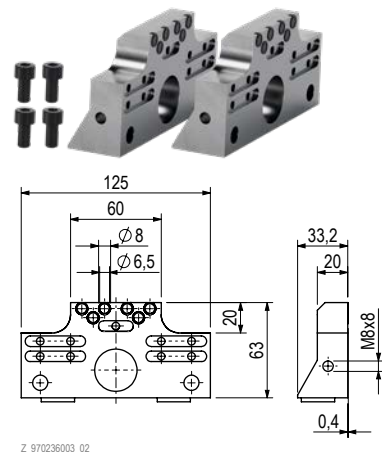

All dimensions in [mm]  
Fastening material included in scope of delivery

### Clamping jaws 125 mm, GripPins

For secure clamping of uneven surfaces such as saw cuts, blanks and cast parts. The clamping jaw has a clamping width of 125mm, the maximum clamping depth is 28mm. Caution: Marks of the pins on the workpiece.

Support rails are required for the clamping jaw. ▶ Page 22

Order no.	Clamping range	Scope of delivery
970236002	0-200mm*	2 pcs. clamping jaws incl. 2 x 9 pcs. GripPins 4 pcs. fixing screws

\*Standard clamping range without extension set

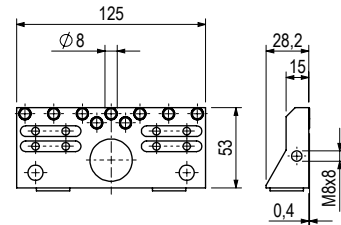

Z\_970236002\_02

All dimensions in [mm]  
Fastening material included in scope of delivery

### Pendulum jaw, GripPins

Pendulum jaws are used to equalise angular errors on the workpiece (max. swivel range 3°). They enable the safe clamping of sawn sections, for example, in a simple way

. Use on one side only.

Caution: Marks of the pins on the workpiece.

Support rails are required for the clamping jaw. ▶ Page 22

Order no.	Clamping range	Scope of delivery
970236009	0-183mm*	1 pc. pendulum jaw 2 pcs. fixing screws

\*Standard clamping range without extension set

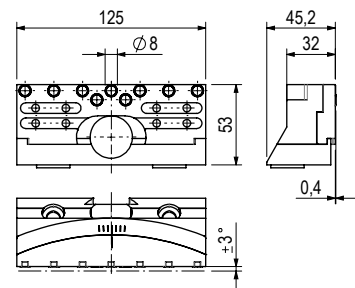

Z\_970236009\_00

All dimensions in [mm]  
Fastening material included in scope of delivery

### GripPins, hardened

If the pins are worn, they can be replaced in the existing clamping jaw.

Caution: Marks of the pins on the workpiece.

Order no.	Scope of delivery
970235004	10 pcs. spare pins

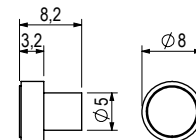

Z\_970235004\_02

All dimensions in [mm]  
Fastening material included in scope of delivery

**INFO**

### Change GripPins

Using a punch, worn pins can be knocked out of the jaw and new ones inserted.

Clamping jaw 125 mm with 9 GripPins



Pendulum jaw with 8 GripPins

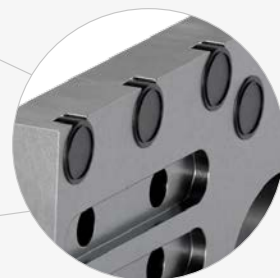
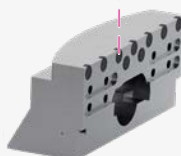

## Vee jaws, hardened

For clamping cylindrical workpieces with a diameter of 8-40mm.  
Workpieces can be clamped horizontally or vertically. With vertical clamping it is possible to place two workpieces in the outer prisms at the same time.  
Support rails are optional for the clamping jaw. ▶ Page 22

Order no.	Clamping range	Scope of delivery
970236004	8-40mm*	2 pcs. Vee jaws 4 pcs. fixing screws

\*Standard clamping range without extension set

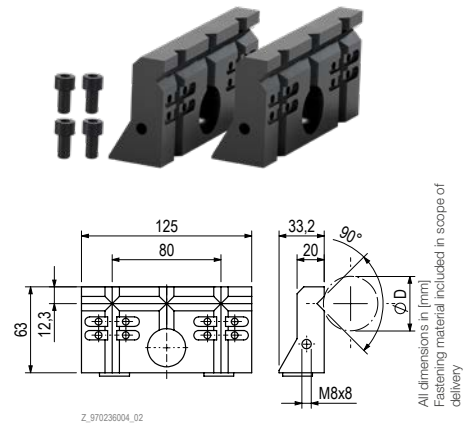

## Set of support rails, hardened

Support rails with 3.5mm and 5.5mm thickness. A support surface for the workpiece is created by attaching the support rails. The clamping depth varies depending on the positioning of the support rail and the selection of the fixation step. The support rails are suitable for all clamping jaws except clamping jaw, soft (970236008) and clamping jaw with round clamping bolt (970236005).

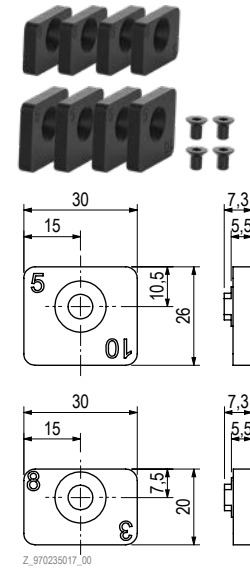
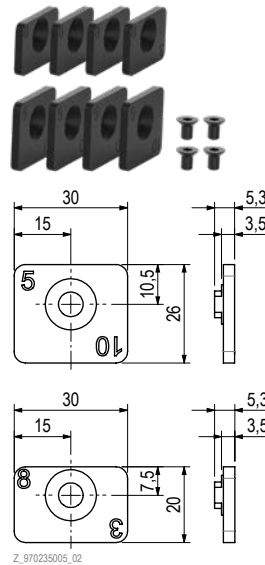

Order no.	Thickness	Clamping range	Scope of delivery
970235005	3.5mm	min. 7 mm	4 pcs. support rails 3.5 mm for 3 mm / 8 mm height of supports 4 pcs. support rails 3.5 mm for 5 mm / 10 mm height of supports 4 pcs. fixing screws
970235017	5.5mm	min. 11 mm	4 pcs. support rails 5.5 mm for 3 mm / 8 mm height of supports 4 pcs. support rails 5.5 mm for 5 mm / 10 mm height of supports 4 pcs. fixing screws

### INFO

### Support rail application

The support rail creates a workpiece support and at the same time determines the clamping depth for the workpiece. The support rail can be aligned according to the desired clamping depth and inserted into the appropriate slot in the clamping jaw.

Support rail	Clamping depth 1. Level	Clamping depth 2. Level	Clamping depth 3. Level
3/8 mm	3mm 8mm	13mm 18mm	23mm 28mm
5/10 mm	5mm 0mm	15mm 10mm	25mm 20mm

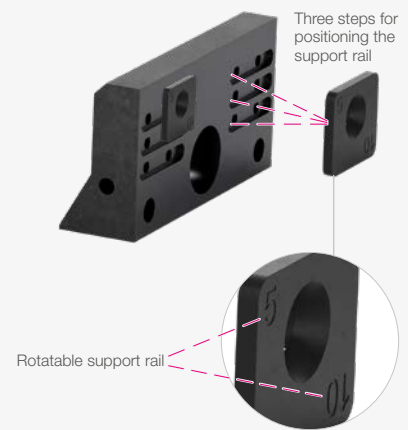

## Soft clamping jaws

Soft jaw for insertion of workpiece-specific clamping contours provided by the customer.

Order no.	Clamping range	Jaw width (A)	Scope of delivery
970236008	0 - 190mm*	125	2 pcs. clamping jaws 4 pcs. fixing screws
9070236013	0 - 190mm*	160	2 pcs. clamping jaws 4 pcs. fixing screws

\*Standard clamping range without extension set

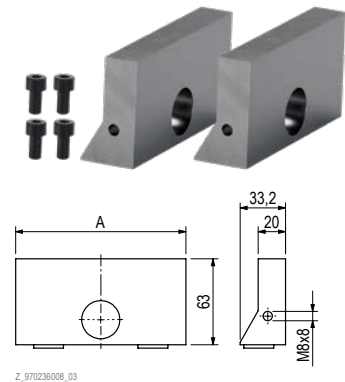

All dimensions in [mm]  
Fastening material included in scope of delivery

## Clamping jaws with round clamping pins

For vertical clamping of cylindrical workpieces with a diameter of 30 bis 200mm. The diameter can be flexibly adjusted by repositioning the inserts. Three- and four-point clamping can be realised. Caution: Clamping marks on the workpiece possible.

Order no.	Clamping range	Scope of delivery
970236005	30 - 200mm*	2 pcs. clamping jaws incl. 4 pcs. round clamping bolt 4 pcs. fixing screws

\*Standard clamping range without extension set

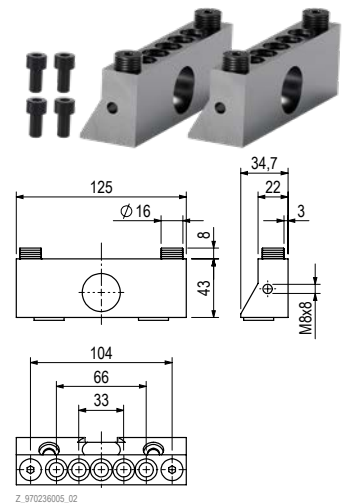

All dimensions in [mm]

## Round clamping bolts

If the round clamping bolts are worn, they can be replaced in the existing clamping jaw. Caution: Marks on the workpiece possible.

Order no.	Scope of delivery
970235016	2 pcs. round clamping bolts

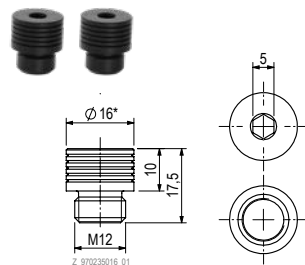

All dimensions in [mm]  
Fastening material included in scope of delivery

### INFO

### Round clamping bolt application

These clamping jaws can be used universally due to the interchangeable round clamping bolts. They can be used for clamping large round plates as well as small cylindrical components.



## Central jaw system

- + Greater flexibility in series production
- + Process-safe handling of heavy workpieces
- + Increased throughput with less set-up time

The central jaw system offers the option of clamping two components simultaneously. It is characterized by its flexibility and can be used both as a fixed central jaw for two components of the same size and as a floating central jaw for components of different sizes.

The base element can also be used to hold the heavy-duty support in order to reliably transfer heavy workpiece weights into the base.

The system has a base that can be fitted to both the standard tensioner and all lower part extensions.

### Central jaw system base

Base for mounting a central jaw. The base can be mounted either floating or clamped. Can be combined with a 125 mm smooth center jaw, 125 mm GripPins center jaw or heavy-duty support.

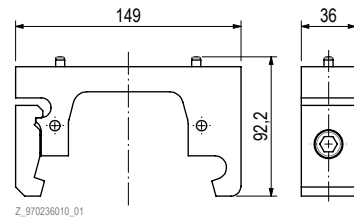

Z\_970236010\_01

All dimensions in [mm]  
Fastening material included in scope of delivery

Order no.	Scope of delivery
970236010	1 pc. center jaw system base with clamping claw and mounting screw

### INFO

#### Application examples



Clamping of two workpieces with the same or different dimensions



Used as a heavy-duty support to support the workpiece weight

### Central jaw 125 mm, smooth, hardened

Central jaw for pull-down clamping jaws - for mounting on the central jaw base. For clamping pre-machined or smooth surfaces (second side). The clamping jaw has a clamping width of 125 mm, the maximum clamping depth is 10 mm. Support rails are optional for the clamping jaw. ▶ Page 22

Order no.	Clamping range	Scope of delivery
970236011	12 - 192 mm*	1 pcs. clamping jaws 2 pcs. fixing screws

\* Standard clamping range without extension set  
Total of clamping widths max. 192 mm

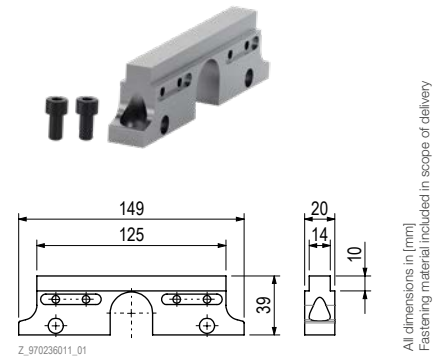

### Central jaw 125 mm, GripPins

Central jaw for GripPins - for mounting on the central jaw base. For secure clamping of uneven surfaces such as saw cuts, blanks and cast parts. The clamping jaw has a clamping width of 125 mm, the maximum clamping depth is 128 mm. Caution: Marks of the pins on the workpiece. Support rails are required for the clamping jaw. ▶ Page 22

Order no.	Clamping range	Scope of delivery
970236012	0 - 180 mm*	1 pcs. clamping jaws incl. 2 x 9 pcs. GripPins 2 pcs. fixing screws

\* Standard clamping range without extension set  
Total of clamping widths max. 180 mm

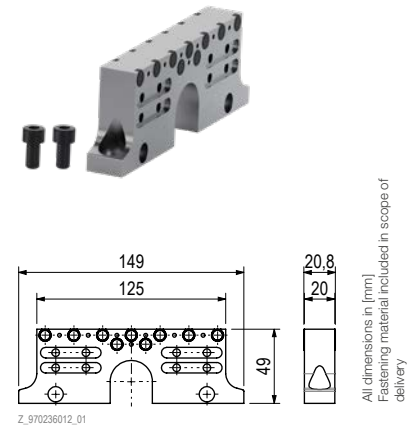

### Heavy-duty support

Support for particularly heavy workpieces. With two heavy-duty supports near the ends of the workpiece, a large-area level is created to place the workpiece with the crane and then close and clamp the tensioner. The support height can be varied using the interchangeable shims; for intermediate dimensions and lower heights, the support screws can be milled over by the customer. Central jaw base 970236010 required. Lower part extensions are required for use in the clamping range > 200 mm.

Order no.	A	B	Scope of delivery
970235055	41 / 40 / 39 mm	9,5 / 8,5 / 7,5 mm	1 pc. heavy-duty support

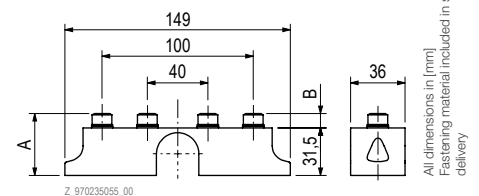

OPTIONS FOR FASTENING ON THE MACHINE TABLE

# Mounting versions

Stable fastening on the machine table is of great importance to ensure precise machining. Depending on the type of machining and the individual requirements, one of the following fastening options can be selected.

Direct mounting

Adapter plate



Keyblocks and screws  
Clamping claws  
Zero point clamping system

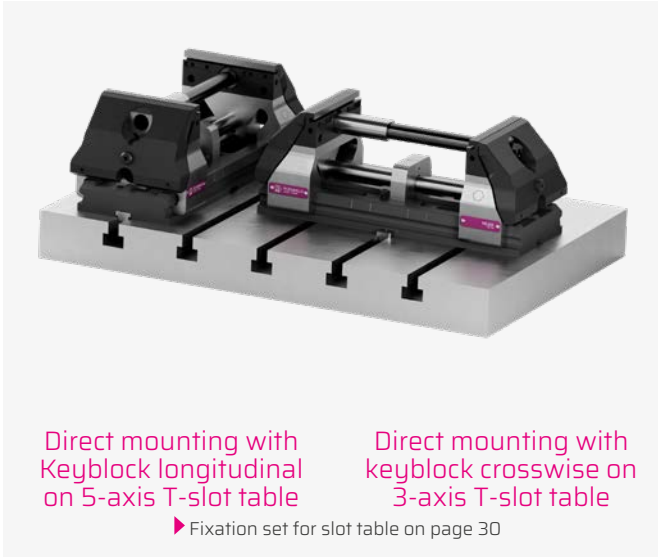

Direct mounting with Keyblock longitudinal on 5-axis T-slot table

► Fixation set for slot table on page 30

Direct mounting with keyblock crosswise on 3-axis T-slot table



Direct mounting with retractable nipples into the STARK zero point clamping system

► Fastening set retractable nipple on page 26

► Fast-closing plates on page 27



Direct mounting with screws from above on hole pattern with raiser on right image

► Raiser on page 29



Direct mounting in a 96 x 96 mm quick die changing system

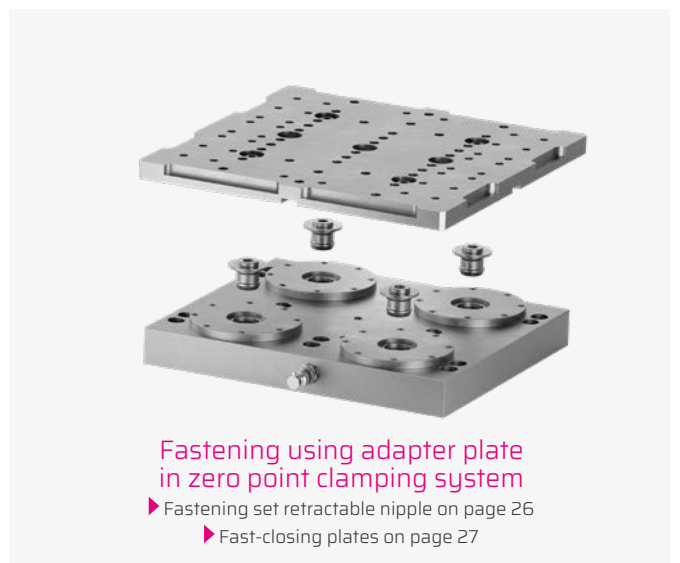

## Retractable nipple for zero point clamping system

Thanks to the integrated retractable nipple bores in the lower part of the vise, HILMA machine vises can be perfectly supplemented and combined with STARK zero-point clamping systems. A zero point clamping system consists of a fast closing clamp in which the

retractable nipples are clamped. In order to compensate for manufacturing tolerances and the necessary "mobility for thermal expansion" on a pallet "temperature variation", three different retractable nipples are combined.

### Draw-in nipple set for SVP STARK.classic.2

Set for direct mounting of the HILMA.UC vise.



### Draw-in nipple set for SVP STARK.basic.M

Set for direct mounting of the HILMA.UC vise.



Order no.	Scope of delivery
970235014	Retractable nipple with zero point STARK.classic.2 NP Screws for mounting from below and above Threaded insert M10
	Retractable nipple with equaliser STARK.classic.2 AG Screws for mounting from below and above Threaded insert M10

Order no.	Scope of delivery
970235015	Retractable nipple with zero point STARK.basic.M NP Screws for mounting from below and above Threaded insert M10
	Retractable nipple with equaliser STARK.basic.M AG Screws for mounting from below and above Threaded insert M10

### Retractable nipple for SVP STARK.classic.2

Individual draw-in nipples for individual combination depending on the application. Threaded inserts are required for the draw-in nipples. ▶ Page 31



### Retractable nipple for SVP STARK.basic.M

Individual draw-in nipples for individual combination depending on the application. Threaded inserts are required for the draw-in nipples. ▶ Page 31



Order no.	Retractable nipple
S804-470	with zero point STARK.classic.2 NP
S804-471	with equaliser STARK.classic.2 AG
S804-472	without centring STARK.classic.2 OZ

Order no.	Retractable nipple
S8000-300	with zero point STARK.basic.M NP
S8000-301	with equaliser STARK.basic.M AG
S8000-302	without centring STARK.basic.M OZ

### Fixing screws & washers for retractable nipple on adaptor plates

Screws & washers for fixation of retractable nipple (STARK.classic.2, STARK.basic.M) on adapter plates ▶ page 30

Order no.	Fixing screws & washers STARK.classic.2
169120086	DIN6912 M12 x 35
104330013	DIN433 washer M12

Order no.	Fixing screws & washers STARK.basic.M
169120084	DIN6912 M12 x 25
104330013	DIN433 washer M12

## Fast closing plate for zero point clamping system

STARK standard fast closing plates (SVP) are a cost-effective entry-level solution for high-quality zero point clamping systems (NPS) and provide a secure and versatile connection between the machine vise and machine table.

- Fast closing plate made of steel ground on both sides with mounting bores for different groove spacings
- NPS is clamped mechanically with spring force and released hydraulically/pneumatically

- Area of application on 3-,4- and 5-axis machines for all common machining procedures such as milling, grinding, eroding

### Standard fast closing plate STARK.classic

- Hydraulic release system
- up to 120kN active insertion force

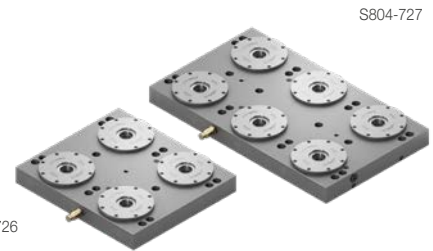

Order no.	Fast closing plate	Size	Spacing
S804-726	Fast closing plate with 4 STARK.classic.2 (S804-452)	4-fold 396 × 346 × 46 mm	200 × 200 mm
S804-727	Fast closing plate with 6 STARK.classic.2 (S804-452)	6-fold 596 × 346 × 46 mm	200 × 200 mm

### Standard fast closing plate STARK.basic

- Pneumatic release system
- up to 54 kN retention force



Order no.	Fast closing plate	Size	Spacing
S805-307	Fast closing plate with 4 STARK.basic.M (S805-202)	4-fold 396 × 346 × 46 mm	200 × 200 mm
S805-308	Fast closing plate with 6 STARK.basic.M (S805-202)	6-fold 596 × 346 × 46 mm	200 × 200 mm

**INFO**

#### Equalisation principle

The selection and arrangement of the retractable nipples depends on their number.

- Retractable nipple with zero point (NP)
- ◐ Retractable nipple with equaliser (AG)
- Retractable nipple without centring (OZ)

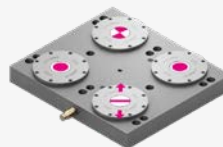

Assignment example  
2-fold adapter plate on 4x SVP  
**NP - OZ**  
**OZ - AG**

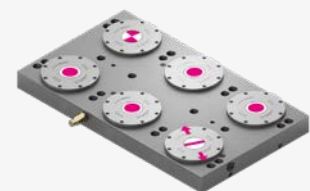

Assignment example  
3-fold adapter plate on 6x SVP  
**NP - OZ**  
**OZ - OZ - AG**

## Adaptor plates

The adapter plates allow the flexibility of the system to be optimally utilised.

- + Simplified mounting
- + Defined interface at the bottom
- + Flexible interface at the top

The slot nuts included in the fixing set allow the HILMA.UC to be positioned precisely on the adapter plate, both in the standard version and in the extended version. Fixing set ► page 32

Order no.	Description	Weight
970235008	1-fold adapter plate 150 × 400 mm Bore holes for retractable nipple* Bore holes for slot nuts and fixing screws	9 kg
970235009	2-fold adapter plate 400 × 400 mm Bore holes for retractable nipple* Bore holes for slot nuts and fixing screws	25 kg
970235010	3-fold adapter plate 600 × 400 mm Bore holes for retractable nipple* Bore holes for slot nuts and fixing screws	37.6 kg

Screws & washers for fixation of retractable nipple on adapter plates ► page 28

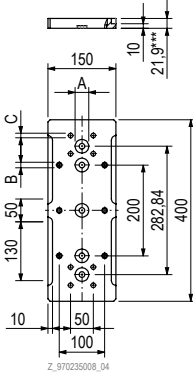
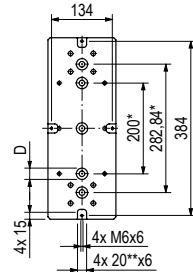

Z\_970235008\_04

A) 5 × Ø 30 - 10 deep; 5 × Ø 12.5 through  
B) 6 × Ø 12 - 14.5 deep; 6 × Ø 8 through  
C) 8 × M12 through  
D) 5 × Ø 25 H7 - 6 deep  
\* Tolerance ± 0.01; \*\* tolerance + 0.02; \*\*\* tolerance + 0.03  
All dimensions and tolerances in [mm]

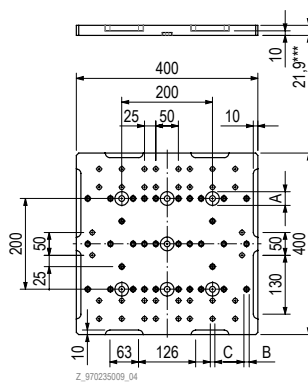
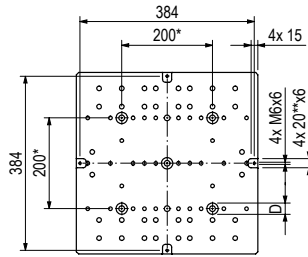
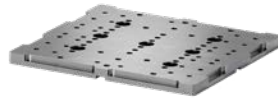

Z\_970235009\_04

A) 7 × Ø 30 - 10 deep; 7 × Ø 12.5 through  
B) 34 × Ø 12 - 14.5 deep; 34 × Ø 8 through  
C) 36 × M12 through  
D) 5 × Ø 25 H7 - 6 deep  
\* Tolerance ± 0.01; \*\* tolerance + 0.02; \*\*\* tolerance + 0.03  
All dimensions and tolerances in [mm]

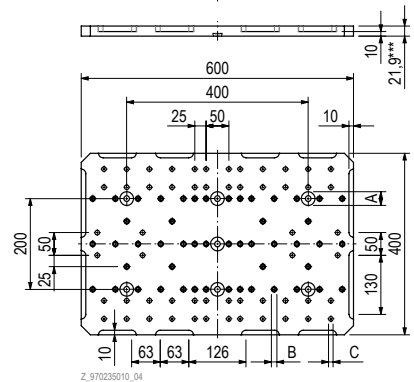
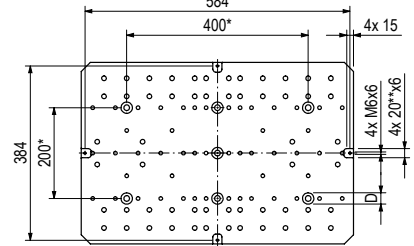

Z\_970235010\_04

A) 7 × Ø 30 - 10 deep; 7 × Ø 12.5 through  
B) 50 × Ø 12 - 14.5 deep; 50 × Ø 8 through  
C) 56 × M12 through  
D) 7 × Ø 25 H7 - 6 deep  
\* Tolerances ± 0.01; \*\* tolerance + 0.02; \*\*\* tolerance + 0.03  
All dimensions and tolerances in [mm]

### INFO

#### Fixing examples on adapter plate



**400 × 400 mm**

Two HILMA.UCs placed next to each other on the outside



**400 × 400 mm**

One HILMA.UC with extension 400 mm placed centrally



**400 × 400 mm**

Two HILMA.UCs with extension 400 mm placed next to each other on the outside



## Fixing sets

### Standard fixing set

For positioning and mounting the clamping system on a T-slot table, hole pattern table or adapter plate.



Order no.	Scope of delivery
970235007	2 pcs. slot nut 14/18mm incl. 2 pcs. cylinder head screws M6×16 mm  4 pcs. T-nut 18 mm 4 pcs. T-nut 14 mm 4 Stk. M12×40mm incl. washers  4 pcs. slot nuts 12×20 mm

### Fixing set with protection against swarf

For positioning and mounting the clamping system on a T-slot table, hole pattern table or adapter plate. Including protection against swarf and stroke limitation.

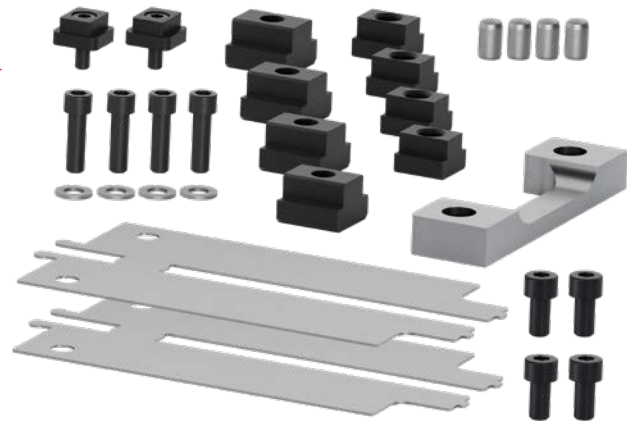

Order no.	Scope of delivery
970235027	2 pcs. slot nut 14/18mm incl. 2 pcs. cylinder head screws M6×16 mm  4 pcs. T-nut 18 mm 4 pcs. T-nut 14 mm 4 pcs. M12×40mm incl. washers  4 pcs. slot nuts 12×20 mm  2 pcs. cover plates, 1 pc. stroke limitation 4 pcs. cylinder head screws M8×10 mm

### Clamping claw set

For mounting adapter plates or clamping systems.

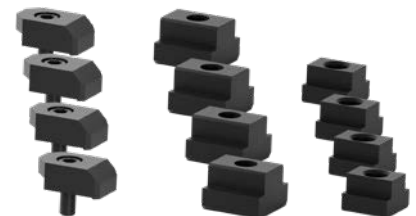

Order no.	Scope of delivery
970235006	4 pcs. clamping claws incl. 4 pc. cylinder head screws M12×30 mm  4 pcs. T-nut 18 mm 4 pcs. T-nut 14 mm

## Accessories

### Hexagonal ball head insert

Hexagonal ball head insert for cordless screwdrivers for convenient operation of the adjustment spindle



Order no.	Scope of delivery
570235028	1 pc. hexagonal ball head insert

► Further accessories such as Allen key and torque wrench on request.

### Inserts for threads

For fixation with STARK draw-in nipples, the standard M16 tapped holes can be reduced to M8/M10/M12 by means of threaded inserts.

Order no.	Scope of delivery
970235011	2 pcs. inserts for M8 thread
970235012	2 pcs. inserts for M10 thread
970235013	2 pcs. inserts for M12 thread

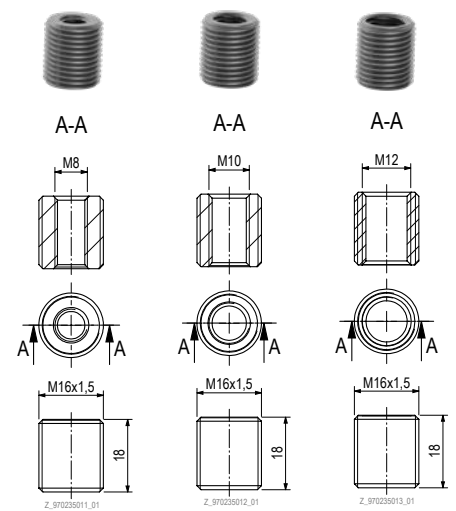

### Support clamping nut

Support for clamping nut when using a lower part extension - recommended for extensions from 600 mm

Order no.	Scope of delivery
970235053	1 pc. support clamping nut incl. fixing screw



### Precision workpiece stop

Swivel-mounted workpiece stop for precise repeat positioning of the component. Not for pendulum jaw or round parts.

Order no.	Scope of delivery
970235030	1 pc. precision workpiece stop incl. fixing screw





## Order number list

104330013	28	970235027	32	970236006	20
104330013	28	970235028	33	970236007	20
169120084	28	970235030	33	970236008	23
169120086	28	970235038	14	970236009	21
970230101	11	970235046	14	970236010	24
970235001	31	970235047	14	970236011	25
970235004	21	970235048	16	970236012	25
970235005	22	970235049	16	970236013	23
970235006	32	970235050	16	S8000-300	28
970235007	32	970235051	16	S8000-301	28
970235008	30	970235052	16	S8000-302	28
970235009	30	970235053	33	S804-470	28
970235010	30	970235055	25	S804-471	28
970235011	33	970235056	14	S804-472	28
970235012	33	970235057	14	S804-726	29
970235013	33	970236001	20	S804-727	29
970235014	28	970236002	21	S805-307	29
970235015	28	970236003	20	S805-308	29
970235016	23	970236004	22		
970235017	22	970236005	23		

A COMPANY OF THE  
ROEMHELD GROUP

# STARK

## Spannsysteme

The ROEMHELD Group is represented in Germany and Austria with different products and orientations. With numerous subsidiaries, sales partners and service companies on all continents and in more than 50 countries, rapid and intensive customer support is provided in the mechanical engineering, medical technology, automotive, aviation and agricultural industries.

As part of the ROEMHELD Group, STARK benefits from the security and experience of a family-run traditional company as well as from the worldwide sales and service network. At the same time, this background provides the independence to pursue dynamic and innovative goals for new market-driven developments and customer-specific solutions with which STARK maintains its leading technological position.



**ROEMHELD**  
HILMA ■ STARK

## **STARK** Spannsysteme

A company of the ROEMHELD Group

STARK Spannsysteme GmbH  
Römergrund 14 | 6830 Rankweil  
Austria

+43 5522 37 400 - 0  
info@stark-roemheld.com

[stark-roemheld.com](http://stark-roemheld.com)