

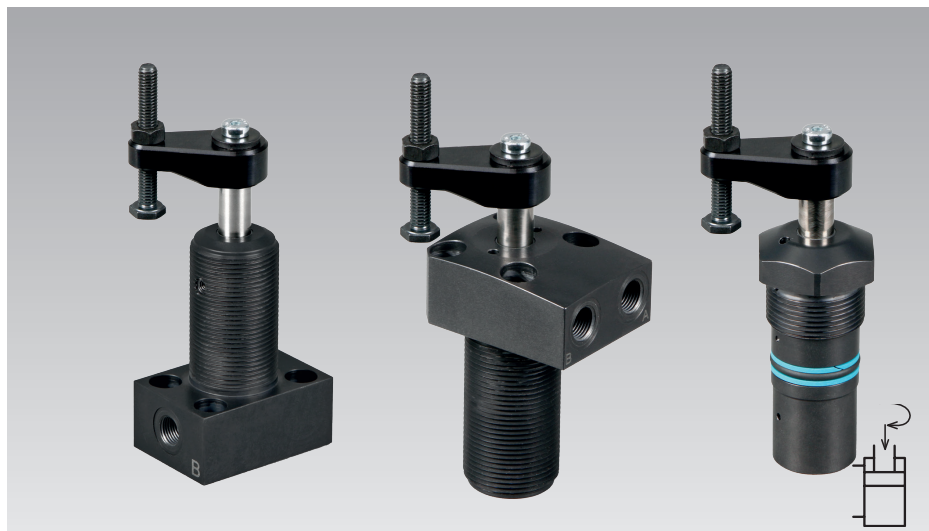

Compact swing clamps with robust sturdy swing mechanism
Bottom flange, top flange, threaded-body type, metal-protected wiper, double-acting, max. operating pressure 350 bar



Advantages

- High clamping force at low operating pressure
- Compact design
- Sturdy swing mechanism
- Metal-protected wiper
- FKM seals as standard
- Special swing angle in standard versions

Application

Hydraulic swing clamps are used for clamping of workpieces when it is essential to keep the clamping area free of straps and clamping components for unrestricted workpiece loading and unloading.

Swing direction

The swing clamps are available with clockwise or counterclockwise swing motion or without swing motion (0°).

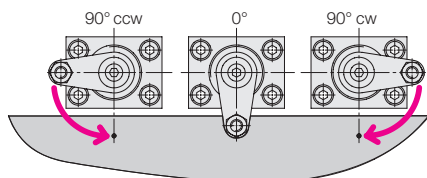

Accessories see page 4

- Clamping arm
- Lock nut

Connecting types

Top flange
pipe threads and drilled channels

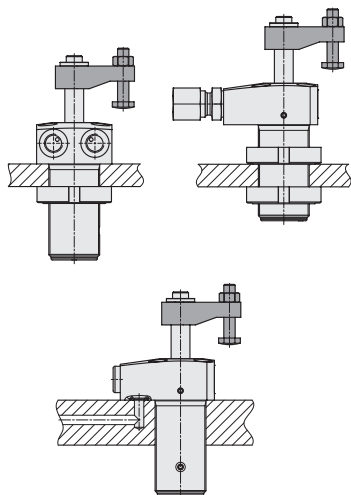

Bottom flange
Pipe thread and drilled channels

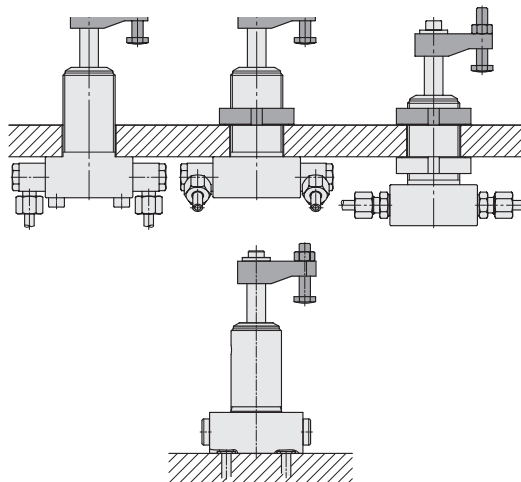

Threaded-body type
Drilled channels

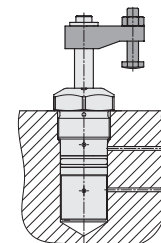

Technical data

Piston Ø	[mm]	14
Rod Ø	[mm]	10
Effective piston area		
Clamping	[cm ²]	0.754
Unclamping	[cm ²]	1.54
Required oil per stroke		
Clamping	[cm ³]	1.2
Unclamping	[cm ³]	2.5
Max. flow rate		
Clamping	[cm ³ /s]	5
Unclamping	[cm ³ /s]	10
Min. operating press.	[bar]	30
Max. operating press.	[bar]	350
Max. pull force	[kN]	2.63
Effect. clamping force	[kN]	see diagram
Swing angle	[°] (0, 45, 60, 90) ±2	
Swing stroke	[mm]	8
Clamping stroke	[mm]	8
Total stroke	[mm]	16

Clamping force diagram

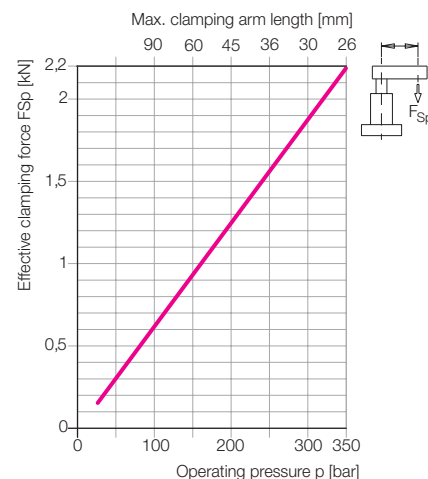

Operating conditions, tolerances and other data see data sheet A 0.100.

Top flange / bottom flange

Top flange

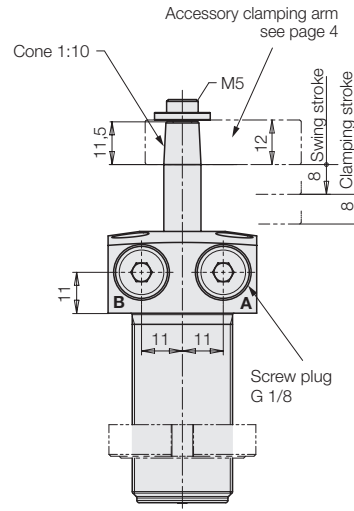
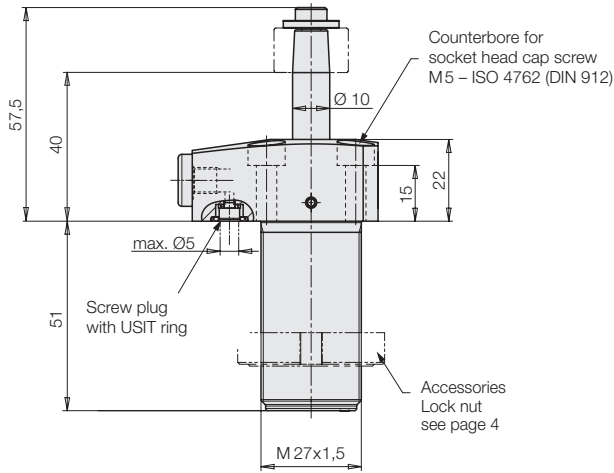

A = Clamping
B = Unclamping

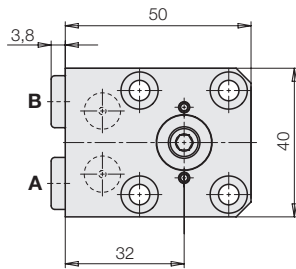

Connecting scheme

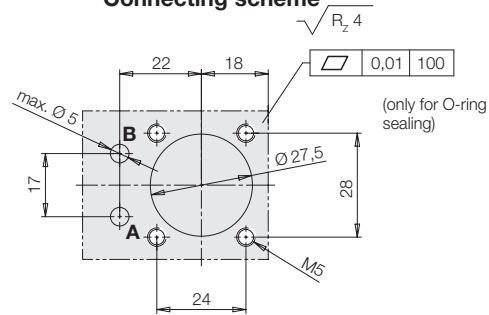

Weight: 0.42 kg

Bottom flange

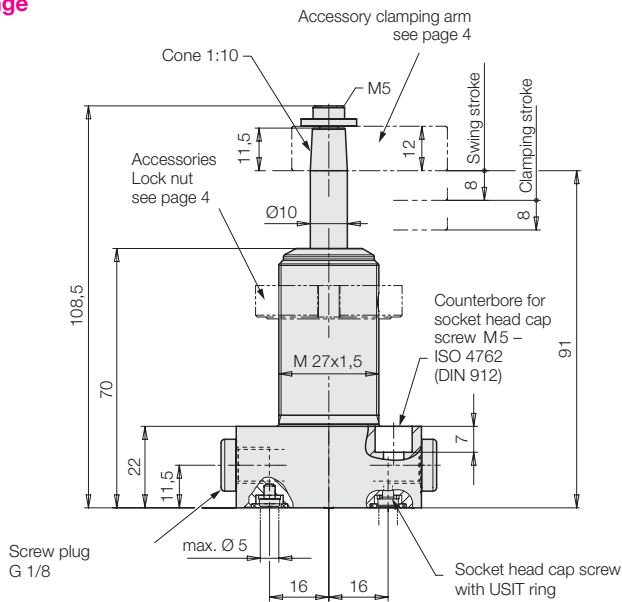

A = Clamping
B = Unclamping

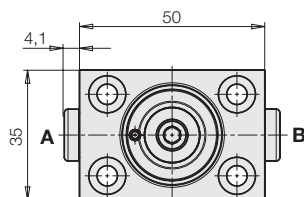

Delivery

Socket head cap screws, screw plugs, and O-rings for the connection with drilled channels are included in the delivery.

Spare-O-ring (FKM):

for top flange: 8 × 1,5 mm,

Part no. 3000275

for bottom flange: 7 × 1,5 mm,

Part no. 3001077

Connecting scheme

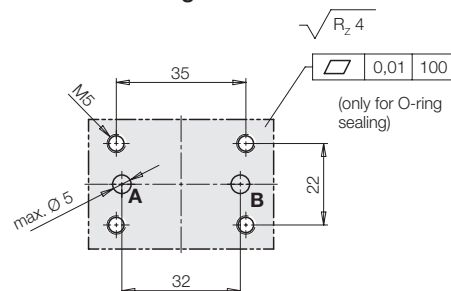

Weight: 0.42 kg

Operating conditions, tolerances and other data see data sheet A 0.100.

Clamping arm, complete
max. 350 bar

Part no. 0354057

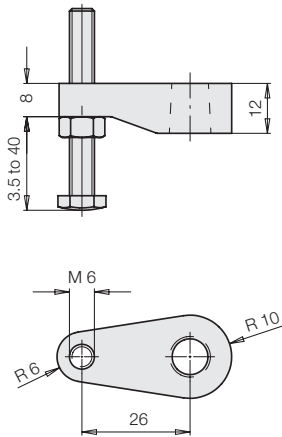

Clamping force diagram

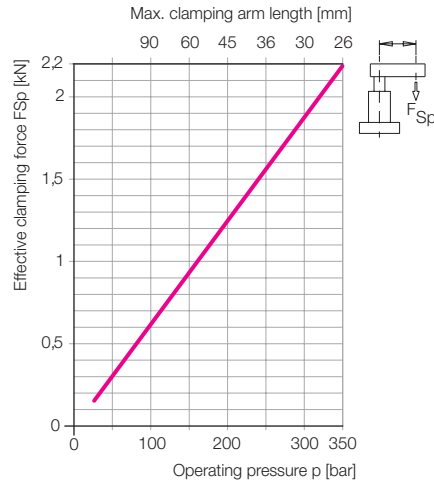

Double clamping arm, complete

Part no. 0354082

Contact bolt M 6 x 45
Part no. 3614138

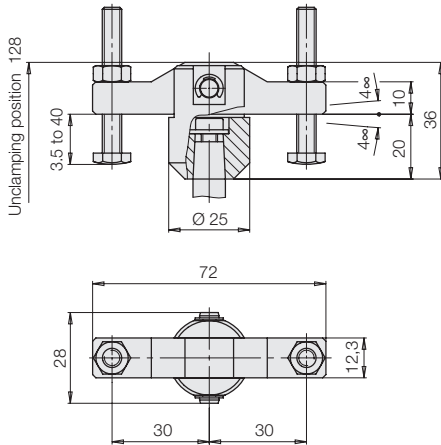

Clamping force diagram

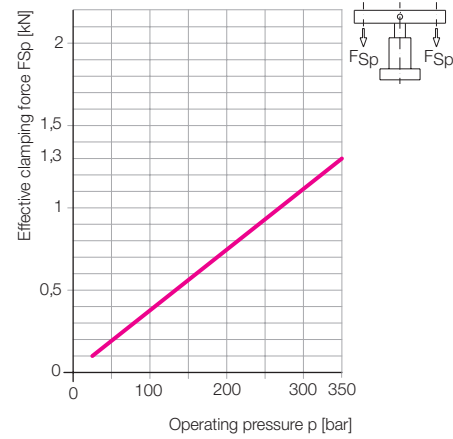

Clamping arm blank

Part no. 3548900

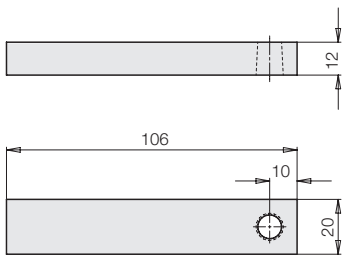

Dimensions for special clamping arms

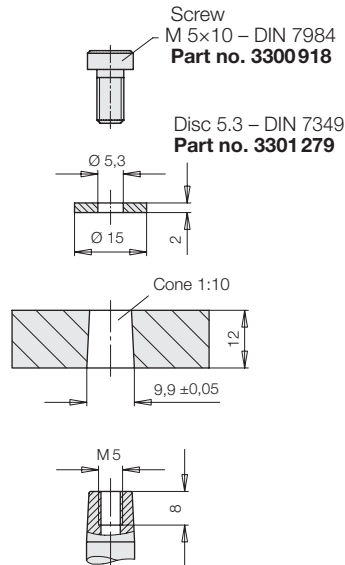

Lock nut as per DIN 1804

Part no. 3527076

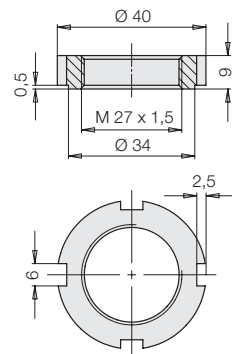

Seal kit, universal for all designs

Part-no. V1SAF01 DFG0001