



Electric Swing Clamp

Top flange, position and clamping force monitoring, IO-Link connection optional
 DC voltage 24 V, minimum energy demand



Application

Electric swing clamps are used for clamping or holding of workpieces

- when the clamping and holding points shall be free for loading and unloading of the fixture
- when an extended functionality is required for automated systems
- when clamping elements have to be controlled individually
- where the clamping force must be maintained also after the separation from the energy supply

Thus electric swing clamps are particularly suited for:

- Packaging industry
- Test systems
- Special machines
- Assembly equipments and robotics
- Automatic manufacturing systems
- Clamping fixtures with workpiece loading via handling systems

Description

The electric swing clamp is driven by a wear-resistant brushless DC motor. The motor speed is transformed by means of a gear and a threaded spindle into the swing and stroke movement of the piston rod. For swinging the clamping arm by 180°, an axial stroke of only 3 mm is required. If the clamping arm collides during the swing motion with a workpiece, the mechanism is protected against overload. The direct current motor is automatically and immediately switched off. When unclamping, the clamping arm always swings back to the off-position.

Integrated control

The electronic control for the DC motor is on a board in the housing of the electric swing clamp.

Electric connection

Power supply and signal exchange for external control are transmitted by two short cables with plug-type connector. Cable sockets are available for the customer's connection (see connection accessories).

Safe touch voltage

The used DC voltage 24 V is considered to be a "low voltage" and thus it is not dangerous for people in case of contact.

Advantages

- High clamping force
- Adjustable clamping force
- Clamping force control
- Can be controlled individually or in common
- High operating safety by self-locking spindle drive
- Mechanical reclamping by Belleville springs
- Swing angle up to 180° available
- Overload protection device in the case of collisions with the clamping arm
- Electrical position monitoring and extended self-monitoring with diagnostic options
- Clamping stroke control possible
- Low voltage 24 V
- Leakage free
- Maintenance free (500,000 cycles)
- Code class IP 67

Power supply

For motor and electronic control a DC voltage of 24 V with a residual ripple of max. 10 % is required.

For the DC motor, we recommend the use of a switching power supply with a current output in accordance with the specifications in the technical data per connected electric swing clamp. When operating several swing clamps at the same time, the line is to be enlarged correspondingly.

The electronic control has to be supplied by a separate power supply (24 V DC / 100 mA).

Adjusting ranges

After removal of the protection cover, the following adjustments can be made on the control board:

- Clamping force
- Swing speed
- Compensation of the clamping arm elasticity

The clamping force can also be adjusted via analogue input.

Important notes

Electric swing clamps are designed exclusively for clamping or holding of workpieces in industrial applications. They can generate very high clamping forces. The workpiece, the fixture or the machine must be in the position to compensate these forces.

In the effective area of piston rod and clamping arm, there is the danger of crushing.

The manufacturer of the fixture or the machine is obliged to provide effective protection devices.

During loading and unloading of the fixture and during clamping a collision with the clamping arm has to be avoided.

For the positioning of workpieces, the admissible displacement force as per diagram on page 4 has to be considered.

If there is any danger that fluids penetrate into the electric swing clamp, the screw plug at the venting port G 1/8 has to be removed and a vent hose has to be connected. The other end of the hose has to be placed to an absolutely dry area. It is recommended to connect a dry positive air pressure protection with 0.2 bar.

Functional principle

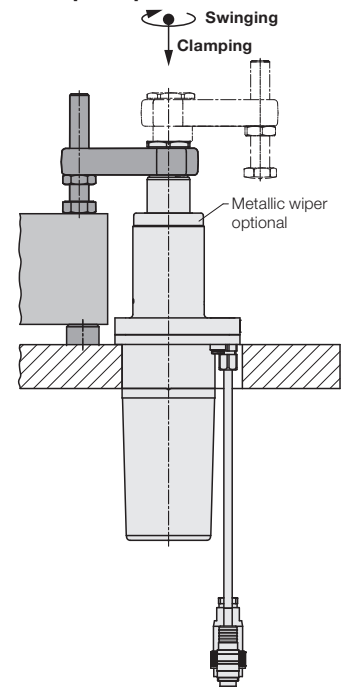

Function control

Unclamped

- Clamping arm in off-position and unclamping process completed

Clamped

- Clamping arm within clamping area and clamping force obtained
- Clamping stroke control possible by output signal

Diagnostic options

- Extensive review on error conditions
- Signalling via error code (flashing signal) internally on control board or via external interface signal
- Error messages can be reset
- Review display after 500,000 cycles

You will find a complete description in the supplied operating manual.

Use **IO-Link**
 Universal · Smart · Easy

Optionally with cable and 4-pin connector for connection to an IO-Link master. Via this interface, commands and information are exchanged between the electric swing clamp and a higher-level control.

Advantages

- Reduced cabling effort
- Simplified commissioning
- More extensive diagnostic options
- Interference immunity through digital signal transmission
- All settings can be made conveniently via the IO-Link interface

Technical information

Further information on the application and operating conditions is available on request.

Dimensions Technical data

Off-position for 180 degree swing angle

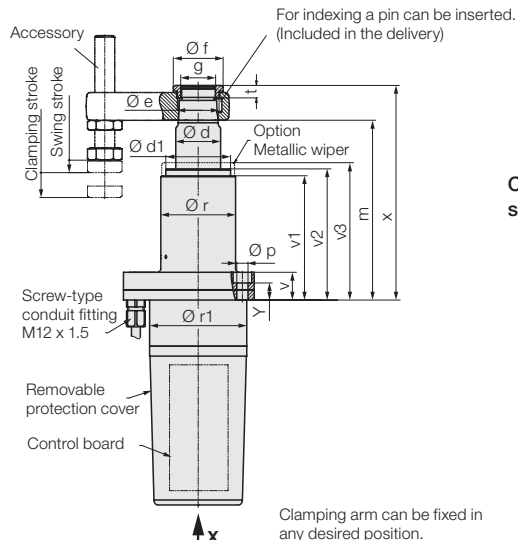

Clamping arm see page 5

183XXXXXXX
183XXXXXXM

Nut included in the delivery
Spare nut see page 5

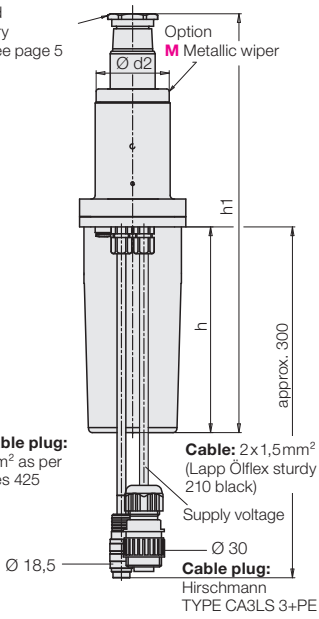

IO-Link connection
183XXXXXXXOI
183XXXXXXXMI

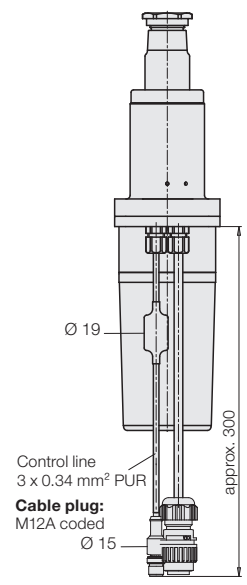

Connecting cable

Maximum permissible cable length 30 m

Cable length	Cable cross section
< 12 m	2 x 1.5 mm²
< 20 m	2 x 2.5 mm²
< 30 m	2 x 4 mm²

Connecting scheme

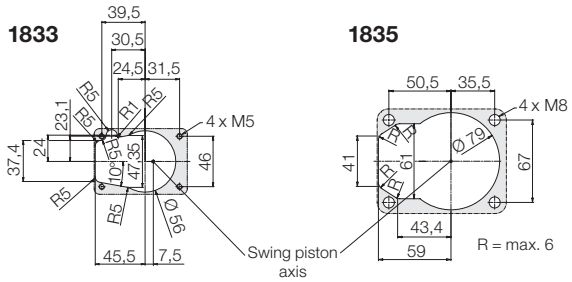

Accessory control line

- Cable socket customized to requirements 12 POL. **Part no. 3141992**
- Cable socket 5 m cable 12 POL. **Part no. 3823375 L 05000**
- Supply line
- Cable socket Hirschmann CA3LD **Part no. 3141991**



Connecting examples Minimum configuration

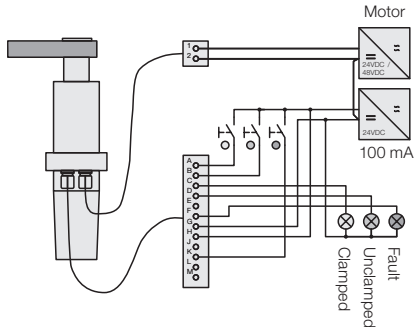

Supply voltage 24 V DC motor

- +24 V DC
- GND (ground)

Control line Pin Function

- A Command clamping
- B Command unclamping
- C Message clamped
- D Message unclamped
- F Message error code
- K Command error reset

Programmable logic control PLC

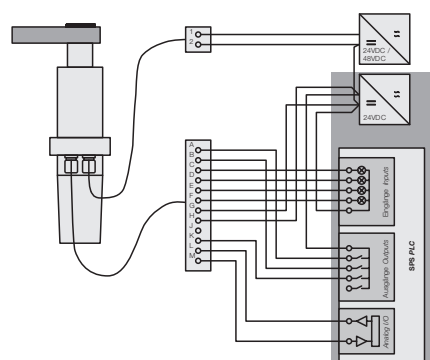

Supply voltage 24 V DC motor

- +24 V DC
- GND (ground)

Control line Pin Function

- A Command clamping
- B Command unclamping
- C Message clamped
- D Message unclamped
- E Message number of cycles
- F Message error code
- G GND (ground)
- H +24 V DC (control)
- K Command error reset
- L Analogue input clamping force (0–10 V)
- M Analogue output clamping stroke (0–10 V)

IO-Link connection

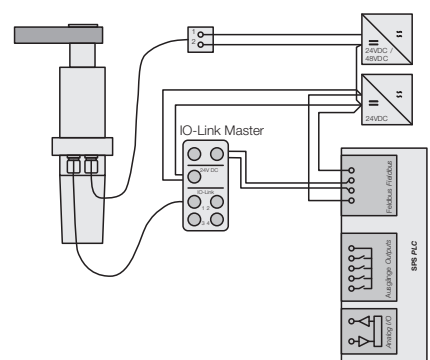

IO-Link connection

Supply voltage 24 V DC motor

- +24 V DC
- GND (ground)

Control line

- +24 V DC
- GND (ground)
- C/Q IO-Link



Dimensions Technical data

Electric Swing Clamp		1833	1835
Axial pulling force adjustable	[kN]	0.9 to 2.7	3 to 9
Effective clamping force	[kN]	see diagram	
Admissible displacement force	[kN]	see diagram	
Clamping stroke (usable)	[mm]	13	20
Swing stroke	[mm]	4	
Total stroke (mechanical)	[mm]	19	26
Swing angle	[°]	0°/90°/180° *	
Clamping time approx.	[s]	3**	
Unclamping time approx.	[s]	3**	
Special clamping arm			
Max. distance between piston axis and clamping point	[mm]	100	150
Max. radial torque M1	[Nm]	0.1	0.5
Max. moment of inertia	[kgm ²]	0.0012	0.008
Nominal voltage	[V DC]	24	
Operating range	[V DC]	22 ... 30	
Residual ripple	[%]	< 10	
Max. current consumption	[A]	8	15
Power consumption in standby mode approx.	[W]	1.2	
Duty cycle	[%]	25 (S3)	
Code class		IP 67	
Positive air pressure connection max.	[bar]	0.2	
Ambient temperature	[°C]	-5 ... +40	
Mounting position		preferably vertical***	
Weight, approx.	[kg]	3.5	8
a	[mm]	39.5	50.5
b	[mm]	31.5	35.5
b1	[mm]	30.5	41.5
b2	[mm]	36.5	50
c	[mm]	46	67
c1	[mm]	11	9
c2	[mm]	24	23.5
Ø d	[mm]	25	36
Ø d1	[mm]	40 s7	52 s6
Ø d2	[mm]	42.8	58.5
Ø e	[mm]	23.5	33.5
f	[mm]	30	40
g	[mm]	M18 × 1.5	M28 × 1.5
h	[mm]	125.5	164.5
h1 +2	[mm]	259.7	336.9
i	[mm]	M5	M8
k	[mm]	60	85
l	[mm]	85	105
m -1	[mm]	115.2	146.4
n	[mm]	38.5	45
Ø p	[mm]	5.5	9
Ø r - 0.1	[mm]	45	60
Ø r1	[mm]	55	78
t	[mm]	9	10
v	[mm]	22.3	22
v1	[mm]	79	99.5
v2	[mm]	83.6	105
v3	[mm]	88.6	110
x +2	[mm]	134.2	172.4
y	[mm]	16.6	13.5

Part no.

Swing direction 90° clockwise	1833A090R19XX	1835C090R26XX
Swing direction 90° counterclockwise	1833A090L19XX	1835C090L26XX
Swing direction 180° clockwise	1833A180R19XX	1835C180R26XX
Swing direction 180° counterclockwise	1833A180L19XX	1835C180L26XX
0 degree	1833A000019XX	1835C000026XX

XX = Options

OI = IO-Link

M = Metallic wiper

MI = Metallic wiper + IO-Link

* Further swing angles are available on request (min. 45°)

** Further technical data available on request

*** For horizontal mounting position, please note page 6

Important note

To guarantee a process-safe application, all technical requirements and general conditions must be carefully checked.

Please contact our technical consultants (on site or directly in product management, Phone +49 6405 89456).

Effective clamping force F_{Sp} as a function of the clamping arm length L

The effective clamping force is smaller the longer the clamping arm. For longer clamping arms, the clamping force must be reduced so that the admissible bending moment will not be exceeded. The adjustment of the clamping force is made on the control board or externally via the analogue input L. The default setting is suitable for the accessory clamping arm with contact bolt.

1833

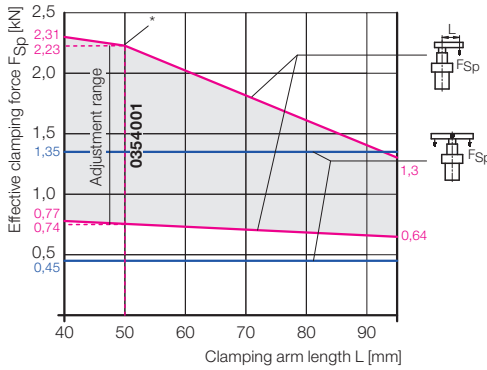

* For clamping arm lengths > 50 mm, please observe the permissible setting parameters for the effective clamping force according to the operating instructions.

1835

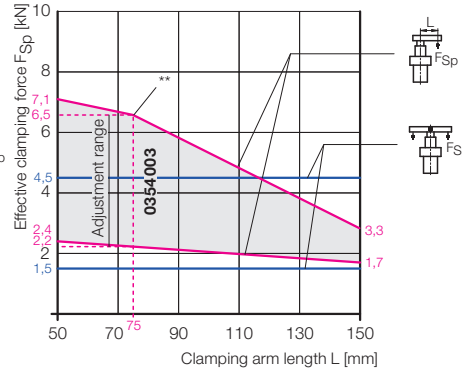

** For clamping arm lengths > 75 mm, please observe the setting parameters permitted for the effective clamping force as specified in the operating instructions.

Example

Accessory clamping arm 0354001: L = 50 mm
As per diagram:
Max. clamping force 2.2 kN
Min. clamping force 0.74 kN
The clamping force is continuously adjustable.

Example

Accessory clamping arm 0354003: L = 75 mm
As per diagram:
Max. clamping force 6.5 kN
Min. clamping force 2.2 kN
The clamping force is continuously adjustable.

Permissible displacement force F_V for the horizontal positioning of a workpiece

$S <$ clamping stroke
The electric swing clamp can push, i.e. position a workpiece against fixed points. The permissible displacement force depends on the set clamping force and the length of the clamping arm. It equal to 15 % of the set clamping force.

A clamping arm with 50 mm centre distance to the clamping point is used. Trimmer F is set to 9. The trimmer E setting is not relevant for the calculation of the displacement force. According to the clamping force diagram, an effective clamping force is achieved at clamping point 2.2 kN. The permissible displacement force F_V is thus:

$$F_V = F_{Sp} * 15 \% = 2.2 \text{ kN} * 0.15 = 0.33 \text{ kN}$$

A clamping arm with 75 mm centre distance to the clamping point is used. Trimmer F is set to 9. The trimmer E setting is not relevant for the calculation of the displacement force. According to the clamping force diagram, an effective clamping force is achieved at clamping point 6.5 kN. The permissible displacement force F_V is thus:

$$F_V = F_{Sp} * 15 \% = 6.5 \text{ kN} * 0.15 = 0.98 \text{ kN}$$

Example

Accessory clamping arm 0354001: L = 50 mm
As per diagram:
Max. clamping force 2.2 kN
Displacement force F_V 0.33 kN
With a friction coefficient $\mu = 0.4$, this is sufficient for a workpiece mass m:

$$m = \frac{F_V}{g * \mu} = \frac{330 \text{ N}}{9.81 * 0.4} = 84 \text{ kg}$$

Example

Accessory clamping arm 0354003: L = 75 mm
As per diagram:
Max. clamping force 6.5 kN
Displacement force F_V 0.98 kN
With a friction coefficient $\mu = 0.4$, this is sufficient for a workpiece mass m:

$$m = \frac{F_V}{g * \mu} = \frac{980 \text{ N}}{9.81 * 0.4} = 250 \text{ kg}$$

Accessory - clamping arm

Dimensions for special clamping arms and indexing

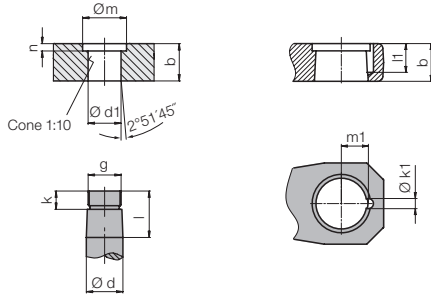

Clamping arm blank with indexing

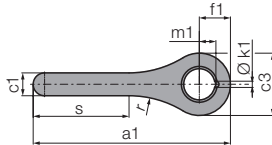

Clamping arm without indexing Clamping arm with contact bolt

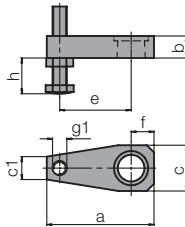

Clamping arm without thread g1

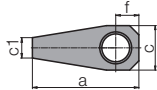

Double clamping arm complete with carrier GGG 40

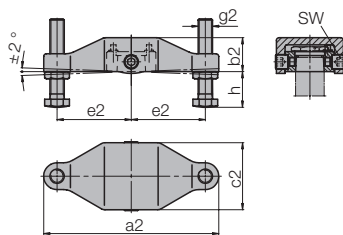

Carrier for double clamping arm 42CrV4 hardened and tempered

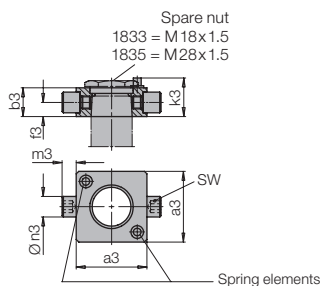

Electric Swing Clamp

		1833	1835
a	[mm]	75	115
a1	[mm]	125	190
a2	[mm]	138	196
a3 ±0.1	[mm]	43	55
b	[mm]	16	23
b2	[mm]	28.5	38
b3 ±0.1	[mm]	16	23
c	[mm]	32	48
c1	[mm]	16	22
c2	[mm]	59	75
c3	[mm]	45	60
Ø d f7	[mm]	25	32
Ø d1 +0.05	[mm]	19.8	31.85
e	[mm]	50	75
e2	[mm]	60	83
f	[mm]	16	25
f1	[mm]	22.5	30
f3	[mm]	7.5	11
g	[mm]	M18×1.5	M28×1.5
g1	[mm]	M10	M16
g2	[mm]	M10	M16
h min ... max	[mm]	10 to 64	15 to 79
k	[mm]	10	12
Ø k1 +0.1	[mm]	3	6
k3**	[mm]	21.5	29
l	[mm]	21	28
l1	[mm]	13	17
Ø m	[mm]	24.5	34
m1 +0.05	[mm]	9.8	16
m3	[mm]	9	11
n	[mm]	4	5
Ø n3 g6	[mm]	10	16
r	[mm]	70	100
s	[mm]	52.7	92.3
SW	[mm]	5	8

Part no.

		0354001	0354003
Clamping arm with contact bolt			
Weight, approx.	[kg]	0.25	0.8
Moment of inertia	[kgm ²]	0.000320	0.002295
Radial torque	[Nm]	0.06	0.32
Clamping arm without thread g1			
Weight, approx.	[kg]	0.2	0.65
Moment of inertia	[kgm ²]	0.00018	0.00134
Radial torque	[Nm]	0.05	0.20
Clamping arm blank			
Weight, approx.	[kg]	0.35	0.95
Moment of inertia	[kgm ²]	0.00074	0.0035
Radial torque	[Nm]	0.1	0.5
Material: High alloy steel 1000... 1200 N/mm ²			
Double clamping arm, complete*			
Weight, approx.	[kg]	0.83	2
Moment of inertia	[kg·m ²]	0.00120	0.00765
Carrier for double clamping arm			
Weight, approx.	[kg]	0.16	0.46
Spare nut			
Max. tightening torque	[Nm]	60	90
Weight, approx.	[kg]	0.03	0.05
Metallic wiper			
		0341231	0341231
		3 m 6x6	6 m6x12
		3301281	3300325

* Complete with threaded bolt and spring elements

** Height stop surface for spring elements

Horizontal mounting position

The electric swing clamp can be operated with the accessory clamping arm with contact bolt (e) in every mounting position.

In the case of longer and heavier special clamping arms, the permissible radial torque $M1^*$ is exceeded, which can lead to malfunctions and increased wear.

Remedy:

Provide the clamping arm with a counterweight as explained in the opposite example.

* see table page 3

Clamping arm S1 with weight compensation S2

$$\text{Required counterweight } m2 = \frac{M1}{l2} \quad [\text{kg}]$$

$M1$ = First-order torque around the piston axis (control of the CAD model) [kgm]

$m2$ = Mass of counterweight [kg]

$l2$ = Centre of gravity of the mass $m2$ [m]

Important note

The additional counterweight increases the moment of inertia J around the piston axis, what can be easily determined by querying of the CAD model. To avoid an overload of the swing drive, the flow rate has to be reduced. The setting is described in the operating manual.

Mounting position - horizontal

